



Built-on components

Contents

Modular design concept _____	14/2
Overview of available components _____	14/3
Brake assignments _____	14/4
Fan assignments _____	14/28

Modular design concept

The design concepts of the different motor series provide for the optional incorporation of components such as encoders, tacho generators, speed monitors, brakes and forced ventilation units to solve the customer's individual control tasks.

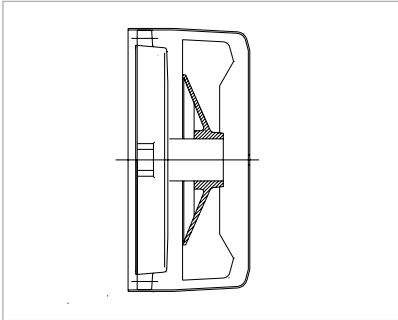

Standard version
Type of cooling IC 411, self-ventilated

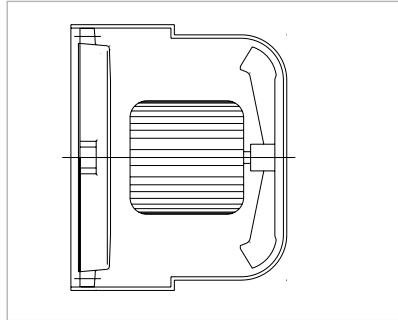

Special version
Type of cooling IC 416, forced ventilation

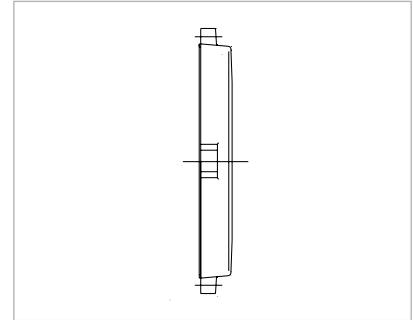

Special version
Type of cooling IC 410, non-ventilated

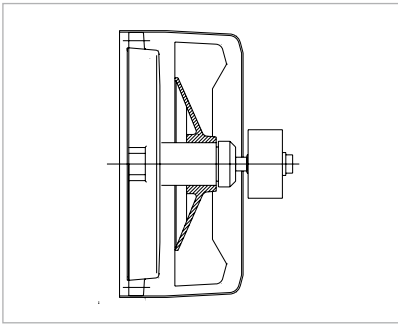

Special version
Type of cooling IC 411, self-ventilated with built-on incremental encoder

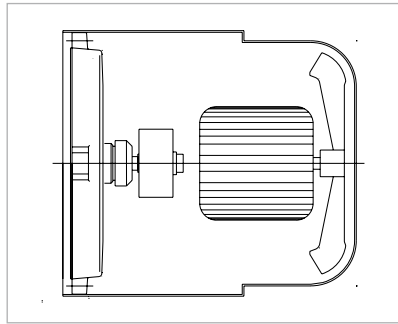

Special version
Type of cooling IC 416, forced ventilation with built-on incremental encoder

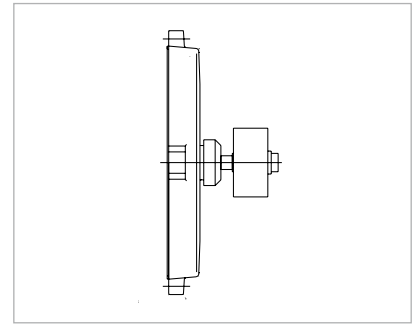

Special version
Type of cooling IC 410, non-ventilated with built-on incremental encoder

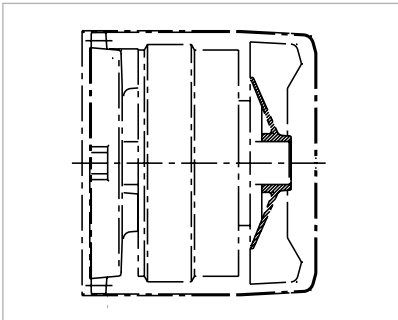

Special version
Type of cooling IC 411, self-ventilated with built-on brake

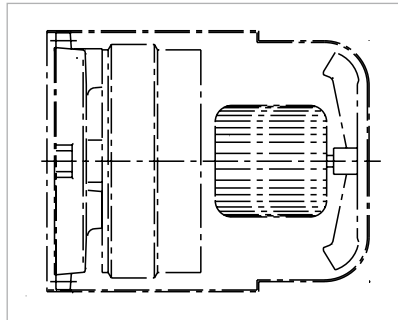

Special version
Type of cooling IC 416, forced ventilation with built-on brake

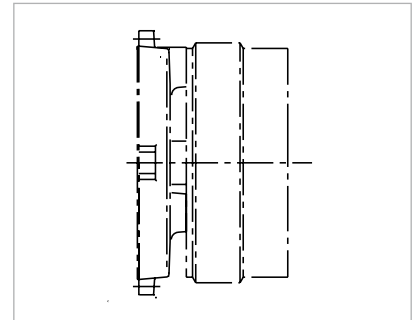

Special version
Type of cooling IC 410, non-ventilated with built-on brake

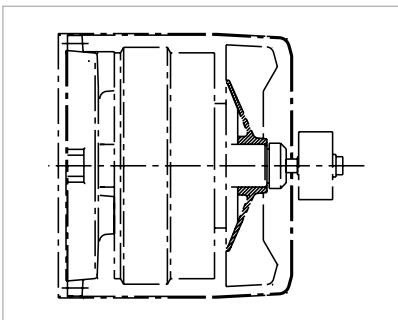

Special version
Type of cooling IC 411, self-ventilated with built-on brake and incremental encoder

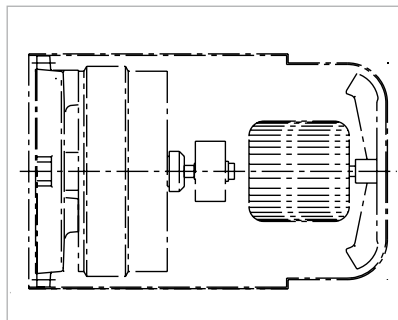

Special version
Type of cooling IC 416, forced ventilation with built-on brake and incremental encoder

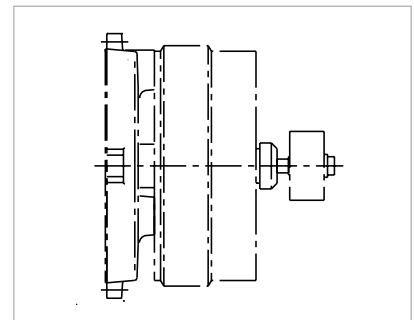

Special version
Type of cooling IC 410, non-ventilated with built-on brake and incremental encoder

Overview of available components

Forced ventilation

Forced ventilation provides for adequate motor cooling at low speeds in converter-fed operation and serves to avoid loud noise at running speeds significantly above the limit speed. The mounting of a fan unit for forced ventilation increases the length and weight of the motor. Binding information on the supply voltage, current and frequency is to be taken from the rating plate.

- Fan unit FBW (Wistro) for use with standard motors
- Fan unit FBI/MMP (Maier) for use with light-duty roller table motors

Brakes

The brakes are designed as spring-operated brakes and fulfil the function of a holding brake. The braking and holding of the motor shaft serves merely to suppress unintentional rotation due to external torques, e.g. the influence of crane loads. The brake function becomes effective at speed $n=0$.

The holding brake must not be used as an operating brake ($n > 0$).

The mounting of a brake increases the overall mass moment of inertia, as well as the length and weight of the motor. Binding information on the brake type, braking torque, supply voltage, frequency, current and thermal class is to be taken from the motor rating plate.

VEM standard brakes

Ex warehouse

Stromag, mounting kit BZFM/BZFA up to size 180

Standard brake motor with integrally mounted brake

Sizes 56 to 132

Stromag, brake BZFM V10, V11, V12 (mounting kit with integrated end shield and fan cowl) from sizes 160

Stromag, series BZFM V7 up to 380 Nm, > 380 Nm 4BZFM up to 4000 Nm

Optionally possible:

Stromag, series NFF, 20 to 10000 Nm

Intorq, series BFK 458, 1.5 to 600 Nm

Mayr, series M, 4 to 1600 Nm

Pintsch-Bubbenzer, series KFB, 50 to 1600 Nm

Pintsch-Bubbenzer, series SFB, 63 to 10000 Nm

Precima, series FDB, 2 to 1500 Nm

Incremental encoders

Ex warehouse

Baumer Thalheim

Type ITD 2. up to and including size 80

Type ITD 4. up to and including size 132

Leine & Linde

Type 861 from size 160 to 250

BEI IDEACOD Inc.

GHM 9 S11

Tacho generator

Johannes Hübner Fabrik elektrischer Maschinen GmbH

TDPH 439 60V with torque arm

Integrated freewheels (backstops)

RINGSPANN GmbH

FXM 66 NX without end cover

FXM 86 NX without end cover

FXM 100 SX with end cover

FXM 120 SX with end cover

Project-specific mounting

Baumer Thalheim GmbH & Co. KG

ITD 40 (radially attached cable 1 m, up to size 132 T 0.5 m)

ITD 41 (radially attached cable 1 m)

ITD 42 (radially attached cable 1 m)

ITD 70 (radially attached cable 1 m)

Baumer Hübner GmbH

Hübner HOG 10 + torque arm

Hübner HOG 9 + torque arm

Hübner POG 9 (centred mounting)

Hübner POG 10 (centred mounting)

Hübner FGJ 2

Brake assignments

2-pole Brake motors Built-on brake with squirrel-cage rotor; Stromag, Intorq brake

Premium Efficiency IE3/High Efficiency IE2/Standard Efficiency IE1 according to IEC/EN 60034-30-1

P _B P _B kW	For motor IE3-	For motor IE2-	For motor (IE1)-B.1R	For motor (IE1)-B.0R	Stromag BZFM	Nm	Stromag NFF	Nm	Intorq BFK	Nm
0.12	IE3-B.1R 56 G2	IE2-B.2R 56 G2	(IE1)-B.1R 56 G2	-	BZFM 0.25	3	-	-	BFK458-06	4
0.18	IE3-B.2R 63 K2	IE2-B.2R 63 K2	(IE1)-B.1R 63 K2	(IE1)-B.0R 56 K2	BZFM 0.25	3	-	-	BFK458-06	4
0.25	IE3-B.1R 63 G2	IE2-BE2R 63 G2	(IE1)-B.1R 63 G2	(IE1)-B.0R 56 G2	BZFM 0.25	3	-	-	BFK458-06	4
0.37	IE3-B.2R 71 K2	IE2-B.2R 71 K2	(IE1)-B.1R 71 K2	(IE1)-B.0R 63 K2	BZFM 0.25	3	-	-	-	-
0.37	IE3-B.2R 71 K2	IE2-B.2R 71 K2	(IE1)-B.1R 71 K2	(IE1)-B.0R 63 K2	BZFM 0.63	6.3	-	-	BFK458-06	4
0.55	-	IE2-B.2R 71 G2	(IE1)-B.1R 71 G2	(IE1)-B.0R 63 G2	BZFM 0.25	3	-	-	-	-
0.55	IE3-B.1R 71 GY2	IE2-B.2R 71 G2	(IE1)-B.1R 71 G2	(IE1)-B.0R 63 G2	BZFM 0.63	6.3	-	-	BFK458-06	4
0.75	-	-	(IE1)-B.1R 80 K2	(IE1)-B.0R 71 K2	BZFM 0.63	6.3	-	-	-	-
0.75	-	-	(IE1)-B.1R 80 K2	(IE1)-B.0R 71 K2	BZFM 1.6	13.5	-	-	BFK458-06	4
0.75	IE3-B.1R 80 K2	IE2-B.1R 80 K2	(IE1)-B.1R 80 K2	(IE1)-B.0R 71 K2	BZFM 1.6	13.5	-	-	BFK458-08	8
1.1	-	-	(IE1)-B.1R 80 G2	(IE1)-B.0R 71 G2	BZFM 0.63	6.3	-	-	-	-
1.1	-	-	(IE1)-B.1R 80 G2	(IE1)-B.0R 71 G2	BZFM 1.6	13.5	-	-	BFK458-06	4
1.1	IE3-B.1R 80 G2	IE2-B.1R 80 G2	(IE1)-B.1R 80 G2	(IE1)-B.0R 71 G2	BZFM 1.6	13.5	-	-	BFK458-08	8
1.5	-	-	(IE1)-B.1R 90 S2	(IE1)-B.0R 80 K2	BZFM 1.6	13.5	-	-	BFK458-06	4
1.5	-	-	(IE1)-B.1R 90 S2	(IE1)-B.0R 80 K2	BZFM 2.5	27	-	-	BFK458-08	8
1.5	IE3-B.1R 90 S2	IE2-B.1R 90 S2	(IE1)-B.1R 90 S2	(IE1)-B.0R 80 K2	BZFM 2.5	27	-	-	BFK458-10	16
2.2	-	-	(IE1)-B.1R 90 L2	(IE1)-B.0R 80 G2	BZFM 1.6	13.5	-	-	BFK458-06	4
2.2	-	-	(IE1)-B.1R 90 L2	(IE1)-B.0R 80 G2	BZFM 2.5	27	-	-	BFK458-08	8
2.2	IE3-B.1R 90 L2	IE2-B.1R 90 L2	(IE1)-B.1R 90 L2	(IE1)-B.0R 80 G2	BZFM 2.5	27	-	-	BFK458-10	16
3.0	-	-	(IE1)-B.1R 100 L2	(IE1)-B.0R 90 L2	BZFM 2.5	27	-	-	BFK458-08	8
3.0	-	-	(IE1)-B.1R 100 L2	(IE1)-B.0R 90 L2	BZFM 4	37	-	-	BFK458-10	16
3.0	IE3-B.1R 100 L2	IE2-B.1R 100 L2	(IE1)-B.1R 100 L2	(IE1)-B.0R 90 L2	BZFM 4	37	-	-	BFK458-12	32
4.0	-	-	(IE1)-B.1R 112 M2	(IE1)-B.0R 100 S2	BZFM 4	37	-	-	BFK458-10	16
4.0	-	-	(IE1)-B.1R 112 M2	(IE1)-B.0R 100 S2	BZFM 6.3	65	-	-	BFK458-12	32
4.0	IE3-B.1R 112 M2T	IE2-B.1R 112 MX2	(IE1)-B.1R 112 M2	(IE1)-B.0R 100 S2	BZFM 6.3	65	-	-	BFK458-14	60
5.5	-	-	(IE1)-B.1R 112 MX2	(IE1)-B.0R 100 L2	-	-	-	-	BFK458-10	16
5.5	-	-	(IE1)-B.1R 112 MX2	(IE1)-B.0R 100 L2	BZFM 4	37	-	-	BFK458-12	32
5.5	-	IE2-B.1R 112 MV2	(IE1)-B.1R 112 MX2	(IE1)-B.0R 100 L2	BZFM 6.3	65	-	-	BFK458-14	60
5.5	-	-	(IE1)-B.1R 132 S2T	(IE1)-B.0R 100 L2	BZFM 4	37	-	-	-	-
5.5	-	-	(IE1)-B.1R 132 S2T	(IE1)-B.0R 100 L2	BZFM 6.3	65	-	-	BFK458-12	32
5.5	-	IE2-B.1R 132 S2T	(IE1)-B.1R 132 S2T	(IE1)-B.0R 100 L2	BZFM 6.3	65	-	-	BFK458-14	60
7.5	-	-	(IE1)-B.1R 112 MV2	(IE1)-B.0R 100 LV2 ^{*)}	BZFM 6.3	65	-	-	BFK458-12	32
7.5	-	-	(IE1)-B.1R 132 SX2T	(IE1)-B.0R 100 LV2 ^{*)}	-	-	-	-	BFK458-12	32
7.5	-	-	(IE1)-B.1R 132 SX2T	(IE1)-B.0R 100 LV2 ^{*)}	BZFM 6.3	65	-	-	BFK458-14	60
5.5	-	-	(IE1)-B.1R 132 S2 ¹⁾	(IE1)-B.0R 112 MY2 ¹⁾	BZFM 6.3	65	-	-	BFK458-12	32
5.5	IE3-B.1R 132 S2	-	(IE1)-B.1R 132 S2 ¹⁾	(IE1)-B.0R 112 MY2 ¹⁾	-	-	-	-	-	-
5.5	IE3-B.1R 132 S2	-	-	-	-	-	-	-	BFK458-14	60
7.5	-	-	(IE1)-B.1R 132 SX2 ¹⁾	(IE1)-B.0R 112 M2 ¹⁾	-	-	-	-	BFK458-12	32
7.5	-	-	(IE1)-B.1R 132 SX2 ¹⁾	(IE1)-B.0R 112 M2 ¹⁾	-	-	-	-	BFK458-12	60
7.5	IE3-B.1R 132 SX2	IE2-B.1R 132 SX2	(IE1)-B.1R 132 SX2 ¹⁾	(IE1)-B.0R 112 M2 ¹⁾	BZFM 6.3	65	-	-	BFK458-14	60
7.5	IE3-B.1R 132 SX2	-	-	-	-	-	-	-	-	-
11.0	-	-	(IE1)-B.1R 160 M2 ¹⁾	(IE1)-B.0R 132 M2 ¹⁾	-	-	-	-	-	-
11.0	IE3-B.1R 160 M2	IE2-B.1R 160 M2	-	-	-	-	-	-	-	-
11.0	-	IE2-B.1R 160 M2	(IE1)-B.1R 160 M2 ¹⁾	(IE1)-B.0R 132 M2 ¹⁾	-	-	NFF 10	100	-	-
11.0	IE3-B.1R 160 M2	IE2-B.1R 160 M2	(IE1)-B.1R 160 M2 ¹⁾	(IE1)-B.0R 132 M2 ¹⁾	BZFM 10	125	-	-	BFK458-16	80
15.0	-	IE2-B.1R 160 MX2	(IE1)-B.1R 160 MX2 ¹⁾	(IE1)-B.0R 160 S2 ¹⁾	-	-	-	-	-	-
15.0	IE3-B.1R 160 MX2	-	-	-	BZFM 10	125	-	-	-	-
15.0	-	IE2-B.1R 160 MX2	(IE1)-B.1R 160 MX2 ¹⁾	(IE1)-B.0R 160 S2 ¹⁾	-	-	-	-	-	-
15.0	IE3-B.1R 160 MX2	IE2-B.1R 160 MX2	(IE1)-B.1R 160 MX2 ¹⁾	(IE1)-B.0R 160 S2 ¹⁾	-	-	-	-	BFK458-18	150
18.5	IE3-B.1R 160 L2	-	-	-	BZFM 10	125	-	-	-	-
18.5	IE3-B.1R 160 L2	IE2-B.1R 160 L2	(IE1)-B.1R 160 L2 ¹⁾	(IE1)-B.0R 160 M2 ¹⁾	-	-	-	-	BFK458-18	150
15.0	-	IE2-B.1R 160 MX2	(IE1)-B.1R 160 MX2 ¹⁾	(IE1)-B.0R 160 S2 ¹⁾	BZFM 10	200	NFF 16	160	-	-
18.5	-	IE2-B.1R 160 L2	(IE1)-B.1R 160 L2 ¹⁾	(IE1)-B.0R 160 M2 ¹⁾	BZFM 16	200	NFF 16	160	-	-
22.0	IE3-B.1R 180 M2C	IE2-B.1R 180 M2	(IE1)-B.1R 180 M2 ¹⁾	(IE1)-B.0R 180 S2 ¹⁾	BZFM 16	200	NFF 25	250	BFK458-20	260
30.0	-	IE2-B.1R 200 L2	(IE1)-B.1R 200 L2 ¹⁾	(IE1)-B.0R 180 M2 ¹⁾	-	-	NFF 25	250	-	-
30.0	IE3-B.1R 200 L2	-	-	-	-	-	-	-	-	-
30.0	IE3-B.1R 200 L2	IE2-B.1R 200 L2	(IE1)-B.1R 200 L2 ¹⁾	(IE1)-B.0R 180 M2 ¹⁾	BZFM 25	380	-	-	BFK458-20	260
30.0	IE3-B.1R 200 LX2C	-	(IE1)-B.1R 200 LX2 ¹⁾	(IE1)-B.0R 200 M2 ¹⁾	-	-	-	-	-	-
37.0	-	-	(IE1)-B.1R 200 LX2 ¹⁾	(IE1)-B.0R 200 M2 ¹⁾	-	-	NFF 40	400	-	-
37.0	-	IE2-B.2R 200 LX2	-	-	-	-	NFF 25	250	-	-
37.0	-	IE2-B.2R 200 LX2	(IE1)-B.1R 200 LX2 ¹⁾	(IE1)-B.0R 200 M2 ¹⁾	-	-	-	-	BFK458-25	400
37.0	IE2-B.1R 200 LX2C	-	-	-	-	-	-	-	BFK458-20	260
37.0	IE3-B.1R 200 LX2C	IE2-B.2R 200 LX2	(IE1)-B.1R 200 LX2 ¹⁾	(IE1)-B.0R 200 M2 ¹⁾	BZFM 25	380	-	-	-	-

2-pole Brake motors Built-on brake with squirrel-cage rotor; Stromag, Intorq brake

Premium Efficiency IE3/High Efficiency IE2/Standard Efficiency IE1 according to IEC/EN 60034-30-1

P _B P _B kW	For motor IE3-	For motor IE2-	For motor (IE1-)B.1R	For motor (IE1-)B.0R	Stromag BZFM	Nm	Stromag NFF	Nm	Intorq BKF	Nm
45.0	-	IE2-B.1R 225 M2	(IE1-)B.1R 225 M2 ¹⁾	(IE1-)B.0R 200 L2 ¹⁾	-	-	NFF 40	400	-	-
45.0	IE3-B.1R 225 M2	-	-	-	-	-	-	-	-	-
45.0	IE3-B.1R 225 M2	IE2-B.1R 225 M2	(IE1-)B.1R 225 M2 ¹⁾	(IE1-)B.0R 200 L2 ¹⁾	BZFM 25	380	-	-	BFK458-25	400
55.0	-	IE2-B.1R 250 M2	(IE1-)B.1R 250 M2 ¹⁾	(IE1-)B.0R 225 M2 ¹⁾	4BZFM 40	400	NFF 63	630	-	-
55.0	IE3-B.1R 250 M2	-	-	-	4BZFM 63	630	-	-	-	-
55.0	IE3-B.1R 250 M2	IE2-B.1R 250 M2	(IE1-)B.1R 250 M2 ¹⁾	(IE1-)B.0R 225 M2 ¹⁾	-	-	-	-	BFK458-25	400
75.0	-	IE2-B.1R 280 S2	(IE1-)B.1R 280 S2 ¹⁾	(IE1-)B.0R 250 S2 ¹⁾	-	-	NFF 63	630	-	-
75.0	IE3-B.1R 280 S2	-	-	-	-	-	-	-	-	-
75.0	IE3-B.1R 280 S2	IE2-B.1R 280 S2	(IE1-)B.1R 280 S2 ¹⁾	(IE1-)B.0R 250 S2 ¹⁾	4BZFM 63	630	-	-	BFK458-25	400
90.0	-	IE2-B.1R 280 M2	(IE1-)B.1R 280 M2 ¹⁾	(IE1-)B.0R 250 M2 ¹⁾	-	-	NFF 100	1000	-	-
90.0	IE3-B.1R 280 M2	IE2-B.1R 280 M2	(IE1-)B.1R 280 M2 ¹⁾	(IE1-)B.0R 250 M2 ¹⁾	4BZFM 63	630	-	-	BFK458-25	400
90.0	IE3-B.1R 280 M2	-	-	-	-	-	-	-	-	-
110.0	-	IE2-B.1R 315 S2	(IE1-)B.1R 315 S2 ¹⁾	(IE1-)B.0R 280 S2 ¹⁾	-	-	NFF 100	1000	-	-
110.0	IE3-B.1R 315 S2	IE2-B.1R 315 S2	(IE1-)B.1R 315 S2 ¹⁾	(IE1-)B.0R 280 S2 ¹⁾	4BZFM 100	1000	-	-	-	-
132.0	-	IE2-B.1R 315 M2	(IE1-)B.1R 315 M2 ¹⁾	(IE1-)B.0R 280 M2 ¹⁾	-	-	NFF 100	1000	-	-
132.0	IE3-B.1R 315 M2	IE2-B.1R 315 M2	(IE1-)B.1R 315 M2 ¹⁾	(IE1-)B.0R 280 M2 ¹⁾	4BZFM 100	1000	-	-	-	-
160.0	-	IE2-B.1R 315 MX2	(IE1-)B.1R 315 MX2 ¹⁾	(IE1-)B.0R 315 S2 ¹⁾	-	-	NFF 100	1000	-	-
160.0	IE3-B.1R 315 MX2	IE2-B.1R 315 MX2	(IE1-)B.1R 315 MX2 ¹⁾	(IE1-)B.0R 315 S2 ¹⁾	4BZFM 100	1000	-	-	-	-
200.0	-	IE2-B.1R 315 MY2	(IE1-)B.1R 315 MY2 ¹⁾	(IE1-)B.0R 315 M2 ¹⁾	-	-	NFF 160	1600	-	-
200.0	IE3-B.1R 315 MY2	IE2-B.1R 315 MY2	(IE1-)B.1R 315 MY2 ¹⁾	(IE1-)B.0R 315 M2 ¹⁾	4BZFM 160	1600	-	-	-	-
250.0	-	IE2-B.1R 315 L2	(IE1-)B.1R 315 L2 ¹⁾	(IE1-)B.0R 315 L2 ¹⁾	-	-	NFF 160	1600	-	-
250.0	IE3-B.1R 315 L2	IE2-B.1R 315 L2	(IE1-)B.1R 315 L2 ¹⁾	(IE1-)B.0R 315 L2 ¹⁾	4BZFM 160	1600	-	-	-	-
315.0	-	IE2-B.1R 315 LX2	(IE1-)B.1R 315 LX2 ¹⁾	(IE1-)B.0R 315 LX2 ¹⁾	-	-	NFF 160	1600	-	-
315.0	IE3-B.1R 315 LX2	IE2-B.1R 315 LX2	(IE1-)B.1R 315 LX2 ¹⁾	(IE1-)B.0R 315 LX2 ¹⁾	4BZFM 160	1600	-	-	-	-
315.0	-	IE2-B.2R 355 MY2	(IE1-)B.2R 355 MY2 ¹⁾	-	-	-	-	-	-	-
315.0	-	IE2-B.2R 355 MY2	(IE1-)B.2R 355 MY2 ¹⁾	-	-	-	NFF 160	1600	-	-
355.0	-	IE2-B.2R 355 M2	(IE1-)B.2R 355 M2 ¹⁾	-	-	-	NFF 160	1600	-	-
355.0	IE3-B.1R 355 M2	IE2-B.2R 355 M2	(IE1-)B.2R 355 M2 ¹⁾	-	4BZFM 160	1600	-	-	-	-
400.0	-	IE2-B.2R 355 MX2	(B.2R 355 MX2 ¹⁾	-	-	-	NFF 160	1600	-	-
400.0	IE3-B.2R 355 MX2	IE2-B.2R 355 MX2	(B.2R 355 MX2 ¹⁾	-	4BZFM 160	1600	-	-	-	-
450.0	-	-	B.2R 355 LY2 ¹⁾	-	-	-	NFF 160	1600	-	-
500.0	-	-	B.2R 355 L2 ¹⁾	-	-	-	NFF 160	1600	-	-
500.0	IE3-B.2R 355 L2	IE2-B.2R 355 L2	B.2R 355 L2 ¹⁾	-	4BZFM 160	1600	-	-	-	-
560.0	IE3-B.2R 400 M2	-	-	-	-	-	-	-	-	-
630.0	IE3-B.2R 400 MX2	-	-	-	-	-	-	-	-	-
710.0	IE3-B.2R 400 L2	-	-	-	-	-	-	-	-	-

Corresponding basic version plus brake and brake mounting (see Extra price list)

Sizes 56–132 T plus rectifier (see Brake accessories)

¹⁾ Flange version only

¹⁾ Requires consultation regarding application

(IE1-) can be supplied with and without marking of IE classification

2-pole Brake motors

Built-on brake with squirrel-cage rotor; Mayr, Pintsch-Bubbenzer, Precima brake

Premium Efficiency IE3/High Efficiency IE2/Standard Efficiency IE1 according to IEC/EN 60034-30-1

P _B P _B KW	For motor IE3-	For motor IE2-	For motor (IE1-)B.1R	For motor (IE1-)B.0R	Mayr M 800/891 (IP 65)	Nm	Pintsch-Bubbenzer KFB/SFB	Nm	Precima FDB	Nm
0.12	IE3-B.1R 56 G2	IE2-B.2R 56 G2	(IE1-)B.1R 56 G2	-	M2/891.	4	-	-	***	***
0.18	IE3-B.2R 63 K2	IE2-B.2R 63 K2	(IE1-)B.1R 63 K2	(IE1-)B.0R 56 K2	M2/891.	4	-	-	***	***
0.25	IE3-B.1R 63 G2	IE2-BE2R 63 G2	(IE1-)B.1R 63 G2	(IE1-)B.0R 56 G2	M2/891.	4	-	-	***	***
0.37	IE3-B.2R 71 K2	IE2-B.2R 71 K2	(IE1-)B.1R 71 K2	(IE1-)B.0R 63 K2	-	-	-	-	***	***
0.37	IE3-B.2R 71 K2	IE2-B.2R 71 K2	(IE1-)B.1R 71 K2	(IE1-)B.0R 63 K2	M4/891.	4	-	-	***	***
0.55	-	IE2-B.2R 71 G2	(IE1-)B.1R 71 G2	(IE1-)B.0R 63 G2	-	-	-	-	***	***
0.55	IE3-B.1R 71 GY2	IE2-B.2R 71 G2	(IE1-)B.1R 71 G2	(IE1-)B.0R 63 G2	M4/891.	4	-	-	***	***
0.75	-	-	(IE1-)B.1R 80 K2	(IE1-)B.0R 71 K2	-	-	-	-	***	***
0.75	-	-	(IE1-)B.1R 80 K2	(IE1-)B.0R 71 K2	-	-	-	-	***	***
0.75	IE3-B.1R 80 K2	IE2-B.1R 80 K2	(IE1-)B.1R 80 K2	(IE1-)B.0R 71 K2	M8/891.	8	-	-	***	***
1.1	-	-	(IE1-)B.1R 80 G2	(IE1-)B.0R 71 G2	-	-	-	-	***	***
1.1	-	-	(IE1-)B.1R 80 G2	(IE1-)B.0R 71 G2	-	-	-	-	***	***
1.1	IE3-B.1R 80 G2	IE2-B.1R 80 G2	(IE1-)B.1R 80 G2	(IE1-)B.0R 71 G2	M8/891.	8	-	-	***	***
1.5	-	-	(IE1-)B.1R 90 S2	(IE1-)B.0R 80 K2	-	-	-	-	***	***
1.5	-	-	(IE1-)B.1R 90 S2	(IE1-)B.0R 80 K2	-	-	-	-	***	***
1.5	IE3-B.1R 90 S2	IE2-B.1R 90 S2	(IE1-)B.1R 90 S2	(IE1-)B.0R 80 K2	M16/891.	16	-	-	***	***
2.2	-	-	(IE1-)B.1R 90 L2	(IE1-)B.0R 80 G2	-	-	-	-	***	***
2.2	-	-	(IE1-)B.1R 90 L2	(IE1-)B.0R 80 G2	-	-	-	-	***	***
2.2	IE3-B.1R 90 L2	IE2-B.1R 90 L2	(IE1-)B.1R 90 L2	(IE1-)B.0R 80 G2	M16/891.	16	-	-	***	***
3.0	-	-	(IE1-)B.1R 100 L2	(IE1-)B.0R 90 L2	-	-	-	-	***	***
3.0	-	-	(IE1-)B.1R 100 L2	(IE1-)B.0R 90 L2	-	-	-	-	***	***
3.0	IE3-B.1R 100 L2	IE2-B.1R 100 L2	(IE1-)B.1R 100 L2	(IE1-)B.0R 90 L2	M32/891.	32	-	-	***	***
4.0	-	-	(IE1-)B.1R 112 M2	(IE1-)B.0R 100 S2	-	-	-	-	***	***
4.0	-	-	(IE1-)B.1R 112 M2	(IE1-)B.0R 100 S2	-	-	-	-	***	***
4.0	IE3-B.1R 112 M2T	IE2-B.1R 112 MX2	(IE1-)B.1R 112 M2	(IE1-)B.0R 100 S2	M60/891.	60	-	-	***	***
5.5	-	-	(IE1-)B.1R 112 MX2	(IE1-)B.0R 100 L2	-	-	-	-	***	***
5.5	-	-	(IE1-)B.1R 112 MX2	(IE1-)B.0R 100 L2	-	-	-	-	***	***
5.5	-	IE2-B.1R 112 MV2	(IE1-)B.1R 112 MX2	(IE1-)B.0R 100 L2	M60/891.	60	-	-	***	***
5.5	-	-	(IE1-)B.1R 132 S2T	(IE1-)B.0R 100 L2	-	-	-	-	***	***
5.5	-	-	(IE1-)B.1R 132 S2T	(IE1-)B.0R 100 L2	-	-	-	-	***	***
5.5	-	IE2-B.1R 132 S2T	(IE1-)B.1R 132 S2T	(IE1-)B.0R 100 L2	M60/891.	60	-	-	***	***
7.5	-	-	(IE1-)B.1R 112 MV2	(IE1-)B.0R 100 LV2*)	M60/891.	60	-	-	***	***
7.5	-	-	(IE1-)B.1R 132 SX2T	(IE1-)B.0R 100 LV2*)	-	-	-	-	***	***
7.5	-	-	(IE1-)B.1R 132 SX2T	(IE1-)B.0R 100 LV2*)	M60/891.	60	-	-	***	***
5.5	-	-	(IE1-)B.1R 132 S2 ¹⁾	(IE1-)B.0R 112 MY2 ¹⁾	-	-	-	-	FDB 15	40
5.5	IE3-B.1R 132 S2	-	(IE1-)B.1R 132 S2 ¹⁾	(IE1-)B.0R 112 MY2 ¹⁾	M32/891.100.1	40	-	-	-	-
5.5	IE3-B.1R 132 S2	-	-	-	-	-	KFB 5	50	FDB 17	60
7.5	-	-	(IE1-)B.1R 132 SX2 ¹⁾	(IE1-)B.0R 112 M2 ¹⁾	-	-	-	-	FDB 15	40
7.5	-	-	(IE1-)B.1R 132 SX2 ¹⁾	(IE1-)B.0R 112 M2 ¹⁾	-	-	-	-	FDB 15	40
7.5	IE3-B.1R 132 SX2	IE2-B.1R 132 SX2	(IE1-)B.1R 132 SX2 ¹⁾	(IE1-)B.0R 112 M2 ¹⁾	M32/891.100.1	64	-	-	FDB 17	60
7.5	IE3-B.1R 132 SX2	-	-	-	-	-	KFB 10	100	-	-
11.0	-	-	(IE1-)B.1R 160 M2 ¹⁾	(IE1-)B.0R 132 M2 ¹⁾	M32/891.100.1	64	-	-	-	-
11.0	IE3-B.1R 160 M2	IE2-B.1R 160 M2	-	-	M60/891.100.1	100	-	-	-	-
11.0	-	IE2-B.1R 160 M2	(IE1-)B.1R 160 M2 ¹⁾	(IE1-)B.0R 132 M2 ¹⁾	-	-	-	-	-	-
11.0	IE3-B.1R 160 M2	IE2-B.1R 160 M2	(IE1-)B.1R 160 M2 ¹⁾	(IE1-)B.0R 132 M2 ¹⁾	-	-	KFB 10	100	FDB 20	100
15.0	-	IE2-B.1R 160 MX2	(IE1-)B.1R 160 MX2 ¹⁾	(IE1-)B.0R 160 S2 ¹⁾	-	-	-	-	-	-
15.0	IE3-B.1R 160 MX2	-	-	-	-	-	KFB 10	100	-	-
15.0	-	IE2-B.1R 160 MX2	(IE1-)B.1R 160 MX2 ¹⁾	(IE1-)B.0R 160 S2 ¹⁾	-	-	KFB 16	160	-	-
15.0	IE3-B.1R 160 MX2	IE2-B.1R 160 MX2	(IE1-)B.1R 160 MX2 ¹⁾	(IE1-)B.0R 160 S2 ¹⁾	M60/891.100.1	100	-	-	FDB 23	150
18.5	IE3-B.1R 160 L2	-	-	-	-	-	KFB 30	175	-	-
18.5	IE3-B.1R 160 L2	IE2-B.1R 160 L2	(IE1-)B.1R 160 L2 ¹⁾	(IE1-)B.0R 160 M2 ¹⁾	M100/891.100.1	180	-	-	FDB 23	150
15.0	-	IE2-B.1R 160 MX2	(IE1-)B.1R 160 MX2 ¹⁾	(IE1-)B.0R 160 S2 ¹⁾	-	-	-	-	-	-
18.5	-	IE2-B.1R 160 L2	(IE1-)B.1R 160 L2 ¹⁾	(IE1-)B.0R 160 M2 ¹⁾	-	-	KFB 16	160	-	-
22.0	IE3-B.1R 180 M2C	IE2-B.1R 180 M2	(IE1-)B.1R 180 M2 ¹⁾	(IE1-)B.0R 180 S2 ¹⁾	M150/891.100.1	150	KFB 30	300	FDB 26	250
30.0	-	IE2-B.1R 200 L2	(IE1-)B.1R 200 L2 ¹⁾	(IE1-)B.0R 180 M2 ¹⁾	M150/891.100.1	250	-	-	-	-
30.0	IE3-B.1R 200 L2	-	-	-	M250/891.100.1	250	-	-	-	-
30.0	IE3-B.1R 200 L2	IE2-B.1R 200 L2	(IE1-)B.1R 200 L2 ¹⁾	(IE1-)B.0R 180 M2 ¹⁾	-	-	KFB 30	300	FDB 26	250
30.0	IE3-B.1R 200 LX2C	-	(IE1-)B.1R 200 LX2 ¹⁾	(IE1-)B.0R 200 M2 ¹⁾	M250/891.100.1	310	-	-	-	-
37.0	-	-	(IE1-)B.1R 200 LX2 ¹⁾	(IE1-)B.0R 200 M2 ¹⁾	-	-	-	-	-	-
37.0	-	IE2-B.2R 200 LX2	-	-	M150/891.100.1	250	-	-	-	-
37.0	-	IE2-B.2R 200 LX2	(IE1-)B.1R 200 LX2 ¹⁾	(IE1-)B.0R 200 M2 ¹⁾	-	-	KFB 40	400	FDB 30	400
37.0	IE2-B.1R 200 LX2C	-	-	-	-	-	KFB 30	300	-	-
37.0	IE3-B.1R 200 LX2C	IE2-B.2R 200 LX2	(IE1-)B.1R 200 LX2 ¹⁾	(IE1-)B.0R 200 M2 ¹⁾	-	-	-	-	-	-

4-pole Brake motors Built-on brake with squirrel-cage rotor; Mayr, Pintsch-Bubenzler, Precima brake

Premium Efficiency IE3/High Efficiency IE2/Standard Efficiency IE1 according to IEC/EN 60034-30-1

P _B P _B KW	For motor IE3-	For motor IE2-	For motor (IE1-)B.1R	For motor (IE1-)B.0R	Mayr M 800/891 (IP 65)	Nm	Pintsch-Bubenzler KFB/SFB	Nm	Precima FDB	Nm
45.0	-	IE2-B.1R 225 M2	(IE1-)B.1R 225 M2 ¹⁾	(IE1-)B.0R 200 L2 ¹⁾	M250/891.100.1	310	-	-	-	-
45.0	IE3-B.1R 225 M2	-	-	-	M500/891.100.1	500	-	-	-	-
45.0	IE3-B.1R 225 M2	IE2-B.1R 225 M2	(IE1-)B.1R 225 M2 ¹⁾	(IE1-)B.0R 200 L2 ¹⁾	-	-	KFB 40	400	FDB 30	400
55.0	-	IE2-B.1R 250 M2	(IE1-)B.1R 250 M2 ¹⁾	(IE1-)B.0R 225 M2 ¹⁾	-	-	-	-	-	-
55.0	IE3-B.1R 250 M2	-	-	-	-	-	-	-	-	-
55.0	IE3-B.1R 250 M2	IE2-B.1R 250 M2	(IE1-)B.1R 250 M2 ¹⁾	(IE1-)B.0R 225 M2 ¹⁾	M500/891.100.1	500	KFB 63	630	FDB 30	400
75.0	-	IE2-B.1R 280 S2	(IE1-)B.1R 280 S2 ¹⁾	(IE1-)B.0R 250 S2 ¹⁾	-	-	-	-	-	-
75.0	IE3-B.1R 280 S2	-	-	-	-	-	-	-	-	-
75.0	IE3-B.1R 280 S2	IE2-B.1R 280 S2	(IE1-)B.1R 280 S2 ¹⁾	(IE1-)B.0R 250 S2 ¹⁾	-	-	KFB 63	630	FDB 30	400
90.0	-	IE2-B.1R 280 M2	(IE1-)B.1R 280 M2 ¹⁾	(IE1-)B.0R 250 M2 ¹⁾	-	-	KFB 100	1000	-	-
90.0	IE3-B.1R 280 M2	IE2-B.1R 280 M2	(IE1-)B.1R 280 M2 ¹⁾	(IE1-)B.0R 250 M2 ¹⁾	-	-	-	-	FDB 30	400
90.0	IE3-B.1R 280 M2	-	-	-	-	-	KFB 63	630	-	-
110.0	-	IE2-B.1R 315 S2	(IE1-)B.1R 315 S2 ¹⁾	(IE1-)B.0R 280 S2 ¹⁾	-	-	-	-	-	-
110.0	IE3-B.1R 315 S2	IE2-B.1R 315 S2	(IE1-)B.1R 315 S2 ¹⁾	(IE1-)B.0R 280 S2 ¹⁾	-	-	KFB 100	1000	-	-
132.0	-	IE2-B.1R 315 M2	(IE1-)B.1R 315 M2 ¹⁾	(IE1-)B.0R 280 M2 ¹⁾	-	-	-	-	-	-
132.0	IE3-B.1R 315 M2	IE2-B.1R 315 M2	(IE1-)B.1R 315 M2 ¹⁾	(IE1-)B.0R 280 M2 ¹⁾	-	-	KFB 100	1000	-	-
160.0	-	IE2-B.1R 315 MX2	(IE1-)B.1R 315 MX2 ¹⁾	(IE1-)B.0R 315 S2 ¹⁾	-	-	-	-	-	-
160.0	IE3-B.1R 315 MX2	IE2-B.1R 315 MX2	(IE1-)B.1R 315 MX2 ¹⁾	(IE1-)B.0R 315 S2 ¹⁾	-	-	KFB 100	1000	-	-
200.0	-	IE2-B.1R 315 MY2	(IE1-)B.1R 315 MY2 ¹⁾	(IE1-)B.0R 315 M2 ¹⁾	-	-	-	-	-	-
200.0	IE3-B.1R 315 MY2	IE2-B.1R 315 MY2	(IE1-)B.1R 315 MY2 ¹⁾	(IE1-)B.0R 315 M2 ¹⁾	-	-	KFB 160	1600	-	-
250.0	-	IE2-B.1R 315 L2	(IE1-)B.1R 315 L2 ¹⁾	(IE1-)B.0R 315 L2 ¹⁾	-	-	-	-	-	-
250.0	IE3-B.1R 315 L2	IE2-B.1R 315 L2	(IE1-)B.1R 315 L2 ¹⁾	(IE1-)B.0R 315 L2 ¹⁾	-	-	KFB 160	1600	-	-
315.0	-	IE2-B.1R 315 LX2	(IE1-)B.1R 315 LX2 ¹⁾	(IE1-)B.0R 315 LX2 ¹⁾	-	-	-	-	-	-
315.0	IE3-B.1R 315 LX2	IE2-B.1R 315 LX2	(IE1-)B.1R 315 LX2 ¹⁾	(IE1-)B.0R 315 LX2 ¹⁾	-	-	KFB 160	1600	-	-
315.0	-	IE2-B.2R 355 MY2	(IE1-)B.2R 355 MY2 ¹⁾	-	-	-	KFB 160	1600	-	-
315.0	-	IE2-B.2R 355 MY2	(IE1-)B.2R 355 MY2 ¹⁾	(IE1-)B.0R 280 M2 ¹⁾	-	-	-	-	-	-
355.0	-	IE2-B.2R 355 M2	(IE1-)B.2R 355 M2 ¹⁾	-	-	-	-	-	-	-
355.0	IE3-B.1R 355 M2	IE2-B.2R 355 M2	(IE1-)B.2R 355 M2 ¹⁾	-	-	-	KFB 160	1600	-	-
400.0	-	IE2-B.2R 355 MX2	(B.2R 355 MX2 ¹⁾	-	-	-	-	-	-	-
400.0	IE3-B.2R 355 MX2	IE2-B.2R 355 MX2	(B.2R 355 MX2 ¹⁾	-	-	-	KFB 160	1600	-	-
450.0	-	-	B.2R 355 LY2 ¹⁾	-	-	-	KFB 160	1600	-	-
500.0	-	-	B.2R 355 L2 ¹⁾	-	-	-	-	-	-	-
500.0	IE3-B.2R 355 L2	IE2-B.2R 355 L2	B.2R 355 L2 ¹⁾	-	-	-	KFB 160	1600	-	-
560.0	IE3-B.2R 400 M2	-	-	-	-	-	-	-	-	-
630.0	IE3-B.2R 400 MX2	-	-	-	-	-	-	-	-	-
710.0	IE3-B.2R 400 L2	-	-	-	-	-	-	-	-	-

Corresponding basic version plus brake and brake mounting (see Extra price list)

Sizes 56–132 T plus rectifier (see Brake accessories)

*) Flange version only

¹⁾ Requires consultation regarding application

(IE1-) can be supplied with and without marking of IE classification

***) upon request

4-pole Brake motors Built-on brake with squirrel-cage rotor; Stromag, Intorq brake

Premium Efficiency IE3/High Efficiency IE2/Standard Efficiency IE1 according to IEC/EN 60034-30-1

P _B P _B KW	For motor IE3-	For motor IE2-	For motor (IE1-)B.1R	For motor (IE1-)B.0R	Stromag BZFM	Nm	Stromag NFF	Nm	Intorq BFK	Nm
0.09	-	-	(IE1-)B.1R 56 G4	-	BZFM 0.25	3	-	-	BFK458-06	4
0.12	IE3-B.2R 63 K4	IE2-BE.2R 63 K4	(IE1-)B.1R 63 K4	(IE1-)B.0R 56 G4	BZFM 0.25	3	-	-	BFK458-06	4
0.18	IE3-B.2R 71 K4	IE2-BE.1R 63 GY4	(IE1-)B.1R 63 G4	(IE1-)B.0R 56 G4	BZFM 0.25	3	-	-	BFK458-06	4
0.25	IE3-B.2R 71 K4	IE2-B.2R 71 K4	(IE1-)B.1R 71 K4	(IE1-)B.0R 63 K4	BZFM 0.25	3	-	-	BFK458-06	4
0.25	IE3-B.2R 71 K4	IE2-B.2R 71 K4	(IE1-)B.1R 71 K4	(IE1-)B.0R 63 K4	BZFM 0.63	6.3	-	-	-	-
0.37	IE3-B.1R 71 GY4	IE2-B.1R 71 GY4	(IE1-)B.1R 71 G4	(IE1-)B.0R 63 G4	BZFM 0.25	3	-	-	BFK458-06	4
0.37	-	-	(IE1-)B.1R 71 G4	(IE1-)B.0R 63 G4	BZFM 0.63	6.3	-	-	-	-
0.55	-	IE2-B.2R 80 K4	(IE1-)B.1R 80 K4	(IE1-)B.0R 71 K4	BZFM 0.63	6.3	-	-	BFK458-06	4
0.55	IE3-B.1R 80 K4	-	(IE1-)B.1R 80 K4	(IE1-)B.0R 71 K4	BZFM 1.6	13.5	-	-	BFK458-08	8
0.75	-	-	(IE1-)B.1R 80 G4	(IE1-)B.0R 71 G4	BZFM 0.63	6.3	-	-	BFK458-06	4
0.75	IE3-B.1R 80 GX4	IE2-B.1R 80 G4	(IE1-)B.1R 80 G4	(IE1-)B.0R 71 G4	BZFM 1.6	13.5	-	-	BFK458-08	8
0.9	-	-	(IE1-)B.1R 80 GX4	(IE1-)B.0R 71 GX4	-	-	-	-	BFK458-06	4
0.9	-	-	(IE1-)B.1R 80 GX4	(IE1-)B.0R 71 GX4	-	-	-	-	BFK458-08	8
1.1	-	-	(IE1-)B.1R 90 S4	(IE1-)B.0R 80 K4	BZFM 1.6	13.5	-	-	BFK458-06	4
1.1	-	-	(IE1-)B.1R 90 S4	(IE1-)B.0R 80 K4	-	-	-	-	BFK458-08	8
1.1	IE3-B.1R 90 S4	IE2-B.1R 90 S4	(IE1-)B.1R 90 S4	(IE1-)B.0R 80 K4	BZFM 2.5	27	-	-	BFK458-10	16
1.5	-	-	(IE1-)B.1R 90 L4	(IE1-)B.0R 80 G4	BZFM 1.6	13.5	-	-	BFK458-06	4
1.5	-	-	(IE1-)B.1R 90 L4	(IE1-)B.0R 80 G4	-	-	-	-	BFK458-08	8
1.5	IE3-B.1R 90 LX4	IE2-B.1R 90 L4	(IE1-)B.1R 90 L4	(IE1-)B.0R 80 G4	BZFM 2.5	27	-	-	BFK458-10	16
2.2	-	-	(IE1-)B.1R 100 L4	(IE1-)B.0R 90 L4	BZFM 2.5	27	-	-	BFK458-08	8
2.2	-	-	(IE1-)B.1R 100 L4	(IE1-)B.0R 90 L4	-	-	-	-	BFK458-10	16
2.2	IE3-B.1R 100 L4	IE2-B.1R 100 L4	(IE1-)B.1R 100 L4	(IE1-)B.0R 90 L4	BZFM 4	37	-	-	BFK458-12	32
3.0	-	-	(IE1-)B.1R 100 LX4	(IE1-)B.0R 100 S4	-	-	-	-	BFK458-10	16
3.0	IE3-B.1R 100 LZ4	IE2-B.1R 100 LX4	(IE1-)B.1R 100 LX4	(IE1-)B.0R 100 S4	BZFM 4	37	-	-	BFK458-12	32
3.0	-	-	(IE1-)B.1R 100 LX4	(IE1-)B.0R 100 S4	BZFM 6.3	65	-	-	BFK458-14	60
4.0	-	-	(IE1-)B.1R 112 M4	(IE1-)B.0R 100 L4	-	-	-	-	BFK458-10	16
4.0	-	-	(IE1-)B.1R 112 M4	(IE1-)B.0R 100 L4	BZFM 4	37	-	-	BFK458-12	32
4.0	IE3-B.1R 112 M4	IE2-B.1R 112 MZ4	(IE1-)B.1R 112 M4	(IE1-)B.0R 100 L4	BZFM 6.3	65	-	-	BFK458-14	60
5.5	-	-	(IE1-)B.1R 112 MX4	(IE1-)B.0R 100 LX4*)	BZFM 4	37	-	-	BFK458-10	16
5.5	-	-	(IE1-)B.1R 112 MX4	(IE1-)B.0R 100 LX4*)	BZFM 6.3	65	-	-	BFK458-12	32
5.5	-	-	(IE1-)B.1R 112 MX4	(IE1-)B.0R 100 LX4*)	-	-	-	-	BFK458-14	60
5.5	-	-	(IE1-)B.1R 132 S4T	(IE1-)B.0R 100 LX4*)	BZFM 4	37	-	-	BFK458-12	32
5.5	-	-	(IE1-)B.1R 132 S4T	(IE1-)B.0R 100 LX4*)	BZFM 6.3	65	-	-	BFK458-14	60
5.5	IE3-B.1R 132 S4	IE2-B.2R 132 S4	(IE1-)B.1R 132 S4	(IE1-)B.0R 112 M4	BZFM 6.3	65	-	-	BFK458-16	80
7.5	-	IE2-B.1R 132 M4	(IE1-)B.1R 132 M4	(IE1-)B.0R 132 S4	-	-	NFF 10	100	-	-
7.5	IE3-B.1R 132 M4	IE2-B.1R 132 M4	(IE1-)B.1R 132 M4	(IE1-)B.0R 132 S4	BZFM 10	125	-	-	BFK458-16	90
11.0	-	IE2-B.2R 160 M4	(IE1-)B.1R 160 M4	(IE1-)B.0R 132 M4	-	-	NFF 10	100	-	-
11.0	IE3-B.1R 160 M4	IE2-B.2R 160 M4	(IE1-)B.1R 160 M4	(IE1-)B.0R 132 M4	BZFM 16	200	-	-	-	-
11.0	IE3-B.1R 160 M4	-	-	-	-	-	-	-	-	-
15.0	-	-	(IE1-)B.1R 160 L4	(IE1-)B.0R 160 S4	BZFM 16	200	NFF 25	250	BFK458-20	260
15.0	-	IE2-B.2R 160 L4	-	-	-	-	NFF 16	160	-	-
15.0	-	IE2-B.2R 160 L4	(IE1-)B.1R 160 L4	(IE1-)B.0R 160 S4	-	-	-	-	-	-
15.0	IE3-B.1R 160 L4C	-	-	-	-	-	-	-	-	-
15.0	IE3-B.1R 160 L4C	IE2-B.2R 160 L4	-	-	BZFM 16	250	-	-	BFK458-20	260
18.5	-	IE2-B.2R 180 M4	(IE1-)B.1R 180 M4	(IE1-)B.0R 160 M4	-	-	NFF 25	250	-	-
18.5	IE3-B.1R 180 M4	IE2-B.2R 180 M4	(IE1-)B.1R 180 M4	(IE1-)B.0R 160 M4	BZFM 16	250	-	-	BFK458-20	260
22.0	-	-	(IE1-)B.1R 180 L4	(IE1-)B.0R 180 S4	-	-	NFF 40	400	BFK458-25	400
22.0	-	IE2-B.1R 180 L4	-	-	-	-	NFF 25	250	BFK458-25	400
22.0	IE3-B.1R 180 L4	-	-	-	-	-	-	-	BFK458-20	290
22.0	-	IE2-B.1R 180 L4	(IE1-)B.1R 180 L4	(IE1-)B.0R 180 S4	-	-	-	-	-	-
22.0	IE3-B.1R 180 L4	IE2-B.1R 180 L4	(IE1-)B.1R 180 L4	(IE1-)B.0R 180 S4	BZFM 25	380	-	-	-	-
30.0	-	IE2-B.1R 200 L4	(IE1-)B.1R 200 L4	(IE1-)B.0R 180 M4	-	-	NFF 40	400	-	-
30.0	IE3-B.1R 200 L4C	-	-	-	-	-	-	-	-	-
30.0	IE3-B.1R 200 L4C	IE2-B.1R 200 L4	(IE1-)B.1R 200 L4	(IE1-)B.0R 180 M4	BZFM 25	380	-	-	BFK458-25	400
37.0	-	-	(IE1-)B.1R 225 S4	(IE1-)B.0R 200 M4	-	-	NFF 63	630	-	-
37.0	-	IE2-B.1R 225 S4	-	-	-	-	NFF 40	400	-	-
37.0	IE3-B.1R 225 S4C	IE2-B.1R 225 S4	(IE1-)B.1R 225 S4	(IE1-)B.0R 200 M4	BZFM 25	380	-	-	BFK458-25	400
37.0	IE3-B.1R 225 S4C	-	-	-	-	-	-	-	-	-
45.0	-	-	(IE1-)B.1R 225 M4	(IE1-)B.0R 200 L4	-	-	NFF 63	630	-	-
45.0	-	IE2-B.1R 225 M4	-	-	-	-	NFF 40	400	-	-
45.0	IE3-B.1R 225 M4	-	-	-	-	-	-	-	-	-
45.0	IE3-B.1R 225 M4	IE2-B.1R 225 M4	(IE1-)B.1R 225 M4	(IE1-)B.0R 200 L4	BZFM 25	380	-	-	BFK458-25	400

4-pole Brake motors Built-on brake with squirrel-cage rotor; Stromag, Intorq brake

Premium Efficiency IE3/High Efficiency IE2/Standard Efficiency IE1 according to IEC/EN 60034-30-1

P _B P _B KW	For motor IE3-	For motor IE2-	For motor (IE1-)B.1R	For motor (IE1-)B.0R	Stromag BZFM	Nm	Stromag NFF	Nm	Intorq BFK	Nm
55.0	-	IE2-B.1R 250 M4	(IE1-)B.1R 250 M4	(IE1-)B.0R 225 M4	-	-	NFF 100	1000	-	-
55.0	IE3-B.1R 250 M4	IE2-B.1R 250 M4	-	-	4BZFM 63	630	-	-	BFK458-25	400
55.0	IE3-B.1R 250 M4	-	-	-	-	-	-	-	-	-
55.0	IE3-B.1R 250 M4	-	-	-	-	-	-	-	-	-
55.0	-	IE2-B.1R 250 M4	-	-	-	-	-	-	-	-
55.0	-	-	(IE1-)B.1R 250 M4	(IE1-)B.0R 225 M4	4BZFM 63	800	-	-	BFK458-25	400
75.0	-	IE2-B.1R 280 S4	(IE1-)B.1R 280 S4	(IE1-)B.0R 250 S4	-	-	NFF 100	1000	-	-
75.0	IE3-B.1R 280 S4	IE2-B.1R 280 S4	(IE1-)B.1R 280 S4	(IE1-)B.0R 250 S4	4BZFM 63	800	-	-	BFK458-25	400
75.0	IE3-B.1R 280 S4	-	-	-	-	-	-	-	-	-
90.0	-	-	(IE1-)B.1R 280 M4	(IE1-)B.0R 250 M4	-	-	-	-	-	-
90.0	-	IE2-B.1R 280 M4	-	-	-	-	-	-	-	-
90.0	-	IE2-B.1R 280 M4	(IE1-)B.1R 280 M4	(IE1-)B.0R 250 M4	-	-	NFF 100	1000	BFK458-25	400
90.0	IE3-B.1R 280 M4	-	-	-	-	-	-	-	-	-
90.0	IE3-B.1R 280 M4	IE2-B.1R 280 M4	(IE1-)B.1R 280 M4	(IE1-)B.0R 250 M4	4BZFM 100	1000	-	-	-	-
110.0	-	IE2-B.1R 315 S4	(IE1-)B.1R 315 S4	(IE1-)B.0R 280 S4	-	-	NFF 160	1600	-	-
110.0	IE3-B.1R 315 S4	IE2-B.1R 315 S4	(IE1-)B.1R 315 S4	(IE1-)B.0R 280 S4	4BZFM 100	1000	-	-	-	-
110.0	IE3-B.1R 315 S4	-	-	-	-	-	-	-	-	-
132.0	-	IE2-B.1R 315 M4	(IE1-)B.1R 315 M4	(IE1-)B.0R 280 M4	-	-	NFF 160	1600	-	-
132.0	IE3-B.1R 315 M4	IE2-B.1R 315 M4	(IE1-)B.1R 315 M4	(IE1-)B.0R 280 M4	4BZFM 100	1000	-	-	-	-
132.0	IE3-B.1R 315 M4	-	-	-	-	-	-	-	-	-
160.0	-	IE2-B.1R 315 MX4	(IE1-)B.1R 315 MX4	(IE1-)B.0R 315 S4	-	-	NFF 160	1600	-	-
160.0	IE3-B.1R 315 MX4	IE2-B.1R 315 MX4	(IE1-)B.1R 315 MX4	(IE1-)B.0R 315 S4	4BZFM 100	1000	-	-	-	-
160.0	IE3-B.1R 315 MX4	-	-	-	-	-	-	-	-	-
200.0	-	IE2-B.1R 315 MY4	(IE1-)B.1R 315 MY4	(IE1-)B.0R 315 M4	-	-	NFF 250	2500	-	-
200.0	IE3-B.1R 315 MY4	-	-	-	-	-	-	-	-	-
200.0	IE3-B.1R 315 MY4	IE2-B.1R 315 MY4	(IE1-)B.1R 315 MY4	(IE1-)B.0R 315 M4	4BZFM 160	1600	-	-	-	-
250.0	-	IE2-B.1R 315 L4	(IE1-)B.1R 315 L4	(IE1-)B.0R 315 L4	-	-	NFF 250	2500	-	-
250.0	IE3-B.1R 315 L4	IE2-B.1R 315 L4	(IE1-)B.1R 315 L4	(IE1-)B.0R 315 L4	4BZFM 160	1600	-	-	-	-
250.0	IE3-B.1R 315 L4	-	-	-	-	-	NFF 250	2500	-	-
315.0	-	IE2-B.1R 315 LX4	(IE1-)B.1R 315 LX4	(IE1-)B.0R 315 LX4	-	-	-	-	-	-
315.0	IE3-B.1R 315 LX4	-	-	-	-	-	-	-	-	-
315.0	IE3-B.1R 315 LX4	IE2-B.1R 315 LX4	(IE1-)B.1R 315 LX4	(IE1-)B.0R 315 LX4	4BZFM 160	1600	-	-	-	-
355.0	-	IE2-B.2R 355 M4	(IE1-)B.2R 355 M4	-	-	-	NFF 400	4000	-	-
355.0	IE3-B.1R 355 M4	-	-	-	-	-	-	-	-	-
355.0	IE3-B.1R 355 M4	IE2-B.2R 355 M4	(IE1-)B.2R 355 M4	-	4BZFM 250	2500	-	-	-	-
400.0	-	IE2-B.2R 355 MX4	(IE1-)B.2R 355 MX4	-	-	-	NFF 400	4000	-	-
400.0	IE3-B.2R 355 MX4	-	-	-	-	-	-	-	-	-
400.0	IE3-B.2R 355 MX4	IE2-B.2R 355 MX4	(IE1-)B.2R 355 MX4	-	4BZFM 250	2500	-	-	-	-
500.0	-	IE2-B.2R 355 L4	(IE1-)B.2R 355 L4	-	-	-	NFF 400	4000	-	-
500.0	IE3-B.2R 355 L4	-	-	-	-	-	-	-	-	-
500.0	IE3-B.2R 355 L4	IE2-B.2R 355 L4	(IE1-)B.2R 355 L4	-	4BZFM 250	2500	-	-	-	-
560.0	IE3-B.2R 400 M4	-	-	-	-	-	***)	-	-	-
630.0	IE3-B.2R 400 MX4	-	-	-	-	-	***)	-	-	-
710.0	IE3-B.2R 400 L4	-	-	-	-	-	***)	-	-	-

Corresponding basic version plus brake and brake mounting (see Extra price list)

Sizes 56–132 T plus rectifier (see Brake accessories)

*) Flange version only

1) Requires consultation regarding application

(IE1-) can be supplied with and without marking of IE classification

***) upon request

4-pole Brake motors

Built-on brake with squirrel-cage rotor; Mayr, Pintsch-Bubbenzer, Precima brake

Premium Efficiency IE3/High Efficiency IE2/Standard Efficiency IE1 according to IEC/EN 60034-30-1

P _B P _B KW	For motor IE3-	For motor IE2-	For motor (IE1-)B.1R	For motor (IE1-)B.0R	Mayr M 800/891 (IP65)	Nm	Pintsch-Bubbenzer KFB/SFB	Nm	Precima FDB	Nm
0.09	-	-	(IE1-)B.1R 56 G4	-	M2/891.	4	-	-	***	***
0.12	IE3-B.2R 63 K4	IE2-BE.2R 63 K4	(IE1-)B.1R 63 K4	(IE1-)B.0R 56 G4	M2/891.	4	-	-	***	***
0.18	IE3-B.2R 71 K4	IE2-BE.1R 63 GY4	(IE1-)B.1R 63 G4	(IE1-)B.0R 56 G4	M2/891.	4	-	-	***	***
0.25	IE3-B.2R 71 K4	IE2-B.2R 71 K4	(IE1-)B.1R 71 K4	(IE1-)B.0R 63 K4	-	-	-	-	***	***
0.25	IE3-B.2R 71 K4	IE2-B.2R 71 K4	(IE1-)B.1R 71 K4	(IE1-)B.0R 63 K4	M4/891.	4	-	-	***	***
0.37	IE3-B.1R 71 GY4	IE2-B.1R 71 GY4	(IE1-)B.1R 71 G4	(IE1-)B.0R 63 G4	-	-	-	-	***	***
0.37	-	-	(IE1-)B.1R 71 G4	(IE1-)B.0R 63 G4	M4/891.	4	-	-	***	***
0.55	-	IE2-B.2R 80 K4	(IE1-)B.1R 80 K4	(IE1-)B.0R 71 K4	-	-	-	-	***	***
0.55	IE3-B.1R 80 K4	-	(IE1-)B.1R 80 K4	(IE1-)B.0R 71 K4	M8/891.	8	-	-	***	***
0.75	-	-	(IE1-)B.1R 80 G4	(IE1-)B.0R 71 G4	-	-	-	-	***	***
0.75	IE3-B.1R 80 GX4	IE2-B.1R 80 G4	(IE1-)B.1R 80 G4	(IE1-)B.0R 71 G4	M8/891.	8	-	-	***	***
0.9	-	-	(IE1-)B.1R 80 GX4	(IE1-)B.0R 71 GX4	-	-	-	-	***	***
0.9	-	-	(IE1-)B.1R 80 GX4	(IE1-)B.0R 71 GX4	-	-	-	-	***	***
1.1	-	-	(IE1-)B.1R 90 S4	(IE1-)B.0R 80 K4	-	-	-	-	***	***
1.1	-	-	(IE1-)B.1R 90 S4	(IE1-)B.0R 80 K4	-	-	-	-	***	***
1.1	IE3-B.1R 90 S4	IE2-B.1R 90 S4	(IE1-)B.1R 90 S4	(IE1-)B.0R 80 K4	M16/891.	16	-	-	***	***
1.5	-	-	(IE1-)B.1R 90 L4	(IE1-)B.0R 80 G4	-	-	-	-	***	***
1.5	-	-	(IE1-)B.1R 90 L4	(IE1-)B.0R 80 G4	-	-	-	-	***	***
1.5	IE3-B.1R 90 LX4	IE2-B.1R 90 L4	(IE1-)B.1R 90 L4	(IE1-)B.0R 80 G4	M16/891.	16	-	-	***	***
2.2	-	-	(IE1-)B.1R 100 L4	(IE1-)B.0R 90 L4	-	-	-	-	***	***
2.2	-	-	(IE1-)B.1R 100 L4	(IE1-)B.0R 90 L4	-	-	-	-	***	***
2.2	IE3-B.1R 100 L4	IE2-B.1R 100 L4	(IE1-)B.1R 100 L4	(IE1-)B.0R 90 L4	M32/891.	32	-	-	***	***
3.0	-	-	(IE1-)B.1R 100 LX4	(IE1-)B.0R 100 S4	-	-	-	-	***	***
3.0	IE3-B.1R 100 LZ4	IE2-B.1R 100 LX4	(IE1-)B.1R 100 LX4	(IE1-)B.0R 100 S4	M32/891.	32	-	-	***	***
3.0	-	-	(IE1-)B.1R 100 LX4	(IE1-)B.0R 100 S4	M60/891.	60	-	-	***	***
4.0	-	-	(IE1-)B.1R 112 M4	(IE1-)B.0R 100 L4	-	-	-	-	***	***
4.0	-	-	(IE1-)B.1R 112 M4	(IE1-)B.0R 100 L4	-	-	-	-	***	***
4.0	IE3-B.1R 112 M4	IE2-B.1R 112 MZ4	(IE1-)B.1R 112 M4	(IE1-)B.0R 100 L4	M60/891.	60	KFB 5	50	***	***
5.5	-	-	(IE1-)B.1R 112 MX4	(IE1-)B.0R 100 LX4*)	-	-	-	-	***	***
5.5	-	-	(IE1-)B.1R 112 MX4	(IE1-)B.0R 100 LX4*)	M60/891.	60	-	-	***	***
5.5	-	-	(IE1-)B.1R 112 MX4	(IE1-)B.0R 100 LX4*)	-	-	-	-	***	***
5.5	-	-	(IE1-)B.1R 132 S4T	(IE1-)B.0R 100 LX4*)	M60/891.	60	-	-	***	***
5.5	-	-	(IE1-)B.1R 132 S4T	(IE1-)B.0R 100 LX4*)	-	-	-	-	***	***
5.5	IE3-B.1R 132 S4	IE2-B.2R 132 S4	(IE1-)B.1R 132 S4	(IE1-)B.0R 112 M4	M32/891.010.1	64	-	-	FDB 20	100
7.5	-	IE2-B.1R 132 M4	(IE1-)B.1R 132 M4	(IE1-)B.0R 132 S4	-	-	-	-	-	-
7.5	IE3-B.1R 132 M4	IE2-B.1R 132 M4	(IE1-)B.1R 132 M4	(IE1-)B.0R 132 S4	M60/891.010.1	100	KFB 10	100	FDB 20	100
11.0	-	IE2-B.2R 160 M4	(IE1-)B.1R 160 M4	(IE1-)B.0R 132 M4	-	-	-	-	-	-
11.0	IE3-B.1R 160 M4	IE2-B.2R 160 M4	(IE1-)B.1R 160 M4	(IE1-)B.0R 132 M4	M100/891.100.1	180	-	-	-	-
11.0	IE3-B.1R 160 M4	-	-	-	-	-	-	-	-	-
15.0	-	-	(IE1-)B.1R 160 L4	(IE1-)B.0R 160 S4	-	-	-	-	FDB 26	250
15.0	-	IE2-B.2R 160 L4	-	-	-	-	-	-	-	-
15.0	-	IE2-B.2R 160 L4	(IE1-)B.1R 160 L4	(IE1-)B.0R 160 S4	-	-	-	-	-	-
15.0	IE3-B.1R 160 L4C	-	-	-	-	-	-	-	-	-
15.0	IE3-B.1R 160 L4C	IE2-B.2R 160 L4	-	-	M100/891.100.1	180	KFB 30	300	FDB 26	250.00
18.5	-	IE2-B.2R 180 M4	(IE1-)B.1R 180 M4	(IE1-)B.0R 160 M4	-	-	-	-	-	-
18.5	IE3-B.1R 180 M4	IE2-B.2R 180 M4	(IE1-)B.1R 180 M4	(IE1-)B.0R 160 M4	M150/891.100.1	250	KFB 30	300	-	-
22.0	-	-	(IE1-)B.1R 180 L4	(IE1-)B.0R 180 S4	-	-	-	-	FDB 30	400
22.0	-	IE2-B.1R 180 L4	-	-	-	-	-	-	FDB 30	400
22.0	IE3-B.1R 180 L4	-	-	-	-	-	-	-	-	-
22.0	-	IE2-B.1R 180 L4	(IE1-)B.1R 180 L4	(IE1-)B.0R 180 S4	-	-	-	-	-	-
22.0	IE3-B.1R 180 L4	IE2-B.1R 180 L4	(IE1-)B.1R 180 L4	(IE1-)B.0R 180 S4	-	-	-	-	-	-
30.0	-	IE2-B.1R 200 L4	(IE1-)B.1R 200 L4	(IE1-)B.0R 180 M4	-	-	-	-	-	-
30.0	IE3-B.1R 200 L4C	-	-	-	-	-	-	-	-	-
30.0	IE3-B.1R 200 L4C	IE2-B.1R 200 L4	(IE1-)B.1R 200 L4	(IE1-)B.0R 180 M4	M250/891.100.1	450	KFB 40	400	FDB 30	400
37.0	-	-	(IE1-)B.1R 225 S4	(IE1-)B.0R 200 M4	-	-	KFB 63	630	-	-
37.0	-	IE2-B.1R 225 S4	-	-	-	-	KFB 63	630	-	-
37.0	IE3-B.1R 225 S4C	IE2-B.1R 225 S4	(IE1-)B.1R 225 S4	(IE1-)B.0R 200 M4	M250/891.100.1	450	-	-	FDB 30	400
37.0	IE3-B.1R 225 S4C	-	-	-	-	-	KFB 40	470	-	-
45.0	-	-	(IE1-)B.1R 225 M4	(IE1-)B.0R 200 L4	-	-	-	-	-	-
45.0	-	IE2-B.1R 225 M4	-	-	-	-	-	-	-	-
45.0	IE3-B.1R 225 M4	-	-	-	-	-	-	-	-	-
45.0	IE3-B.1R 225 M4	IE2-B.1R 225 M4	(IE1-)B.1R 225 M4	(IE1-)B.0R 200 L4	M500/891.100.1	500	KFB 63	630	FDB 30	400

4-pole Brake motors Built-on brake with squirrel-cage rotor; Mayr, Pintsch-Bubenzler, Precima brake

Premium Efficiency IE3/High Efficiency IE2/Standard Efficiency IE1 according to IEC/EN 60034-30-1

P _B P _B KW	For motor IE3-	For motor IE2-	For motor (IE1-)B.1R	For motor (IE1-)B.0R	Mayr M 800/891 (IP 65)	Nm	Pintsch-Bubenzler KFB/SFB	Nm	Precima FDB	Nm
55.0	-	IE2-B.1R 250 M4	(IE1-)B.1R 250 M4	(IE1-)B.0R 225 M4	-	-	-	-	-	-
55.0	IE3-B.1R 250 M4	IE2-B.1R 250 M4	-	-	M500/891.100.1	500	-	-	FDB 30	400
55.0	IE3-B.1R 250 M4	-	-	-	-	-	KFB 63	630	-	-
55.0	IE3-B.1R 250 M4	-	-	-	-	-	-	-	-	-
55.0	-	IE2-B.1R 250 M4	-	-	-	-	-	-	-	-
55.0	-	-	(IE1-)B.1R 250 M4	(IE1-)B.0R 225 M4	-	-	KFB 100	1000	FDB 30	400
75.0	-	IE2-B.1R 280 S4	(IE1-)B.1R 280 S4	(IE1-)B.0R 250 S4	-	-	KFB 100	1000	-	-
75.0	IE3-B.1R 280 S4	IE2-B.1R 280 S4	(IE1-)B.1R 280 S4	(IE1-)B.0R 250 S4	M500/891.100.1	500	-	-	FDB 30	400
75.0	IE3-B.1R 280 S4	-	-	-	-	-	KFB 63	630	-	-
90.0	-	-	(IE1-)B.1R 280 M4	(IE1-)B.0R 250 M4	-	-	-	-	-	-
90.0	-	IE2-B.1R 280 M4	-	-	-	-	-	-	-	-
90.0	-	IE2-B.1R 280 M4	(IE1-)B.1R 280 M4	(IE1-)B.0R 250 M4	-	-	-	-	FDB 30	400
90.0	IE3-B.1R 280 M4	-	-	-	-	-	-	-	-	-
90.0	IE3-B.1R 280 M4	IE2-B.1R 280 M4	(IE1-)B.1R 280 M4	(IE1-)B.0R 250 M4	-	-	KFB 100	1000	-	-
110.0	-	IE2-B.1R 315 S4	(IE1-)B.1R 315 S4	(IE1-)B.0R 280 S4	-	-	KFB 160	1600	-	-
110.0	IE3-B.1R 315 S4	IE2-B.1R 315 S4	(IE1-)B.1R 315 S4	(IE1-)B.0R 280 S4	-	-	-	-	-	-
110.0	IE3-B.1R 315 S4	-	-	-	M1000/891.010.1	800	KFB 100	1000	-	-
132.0	-	IE2-B.1R 315 M4	(IE1-)B.1R 315 M4	(IE1-)B.0R 280 M4	-	-	KFB 160	1600	-	-
132.0	IE3-B.1R 315 M4	IE2-B.1R 315 M4	(IE1-)B.1R 315 M4	(IE1-)B.0R 280 M4	-	-	-	-	-	-
132.0	IE3-B.1R 315 M4	-	-	-	M1000/891.010.1	1000	KFB 100	1000	-	-
160.0	-	IE2-B.1R 315 MX4	(IE1-)B.1R 315 MX4	(IE1-)B.0R 315 S4	-	-	-	-	-	-
160.0	IE3-B.1R 315 MX4	IE2-B.1R 315 MX4	(IE1-)B.1R 315 MX4	(IE1-)B.0R 315 S4	-	-	KFB 160	1600	-	-
160.0	IE3-B.1R 315 MX4	-	-	-	-	-	-	-	-	-
200.0	-	IE2-B.1R 315 MY4	(IE1-)B.1R 315 MY4	(IE1-)B.0R 315 M4	-	-	SFB 250	2500	-	-
200.0	IE3-B.1R 315 MY4	-	-	-	-	-	KFB 160	1600	-	-
200.0	IE3-B.1R 315 MY4	IE2-B.1R 315 MY4	(IE1-)B.1R 315 MY4	(IE1-)B.0R 315 M4	-	-	-	-	-	-
250.0	-	IE2-B.1R 315 L4	(IE1-)B.1R 315 L4	(IE1-)B.0R 315 L4	-	-	SFB 250	2500	-	-
250.0	IE3-B.1R 315 L4	IE2-B.1R 315 L4	(IE1-)B.1R 315 L4	(IE1-)B.0R 315 L4	-	-	-	-	-	-
250.0	IE3-B.1R 315 L4	-	-	-	-	-	KFB 160	1600	-	-
315.0	-	IE2-B.1R 315 LX4	(IE1-)B.1R 315 LX4	(IE1-)B.0R 315 LX4	-	-	SFB 250	2500	-	-
315.0	IE3-B.1R 315 LX4	-	-	-	-	-	SFB 250	2500	-	-
315.0	IE3-B.1R 315 LX4	IE2-B.1R 315 LX4	(IE1-)B.1R 315 LX4	(IE1-)B.0R 315 LX4	-	-	-	-	-	-
355.0	-	IE2-B.2R 355 M4	(IE1-)B.2R 355 M4	-	-	-	SFB 250/330	3300	-	-
355.0	IE3-B.1R 355 M4	-	-	-	-	-	SFB 250	2500	-	-
355.0	IE3-B.1R 355 M4	IE2-B.2R 355 M4	(IE1-)B.2R 355 M4	-	-	-	-	-	-	-
400.0	-	IE2-B.2R 355 MX4	(IE1-)B.2R 355 MX4	-	-	-	SFB 250/330	3300	-	-
400.0	IE3-B.2R 355 MX4	-	-	-	-	-	SFB 250	3300	-	-
400.0	IE3-B.2R 355 MX4	IE2-B.2R 355 MX4	(IE1-)B.2R 355 MX4	-	-	-	-	-	-	-
500.0	-	IE2-B.2R 355 L4	(IE1-)B.2R 355 L4	-	-	-	SFB 250/330	3300	-	-
500.0	IE3-B.2R 355 L4	-	-	-	-	-	SFB 250	3300	-	-
500.0	IE3-B.2R 355 L4	IE2-B.2R 355 L4	(IE1-)B.2R 355 L4	-	-	-	-	-	-	-
560.0	IE3-B.2R 400 M4	-	-	-	-	-	***	-	-	-
630.0	IE3-B.2R 400 MX4	-	-	-	-	-	***	-	-	-
710.0	IE3-B.2R 400 L4	-	-	-	-	-	***	-	-	-

Corresponding basic version plus brake and brake mounting (see Extra price list)

Sizes 56–132 T plus rectifier (see Brake accessories)

*) Flange version only

1) Requires consultation regarding application

(IE1-) can be supplied with and without marking of IE classification

***) upon request

6-pole Brake motors Built-on brake with squirrel-cage rotor; Stromag, Intorq brake

Premium Efficiency IE3/High Efficiency IE2/Standard Efficiency IE1 according to IEC/EN 60034-30-1

P _B P _B KW	For motor IE3-	For motor IE2-	For motor (IE1-)B.1R	For motor (IE1-)B.0R	Stromag BZFM	Nm	Stromag NFF	Nm	Intorq BFK	Nm
0.09	-	-	(IE1-)B.1R 63 K6	(IE1-)B.0R 56 K6	BZFM 0.25	3	-	-	BFK 458-06	4
0.12	IE3-B.1R 63 G6	IE2-B.2R 63 G6	(IE1-)B.1R 63 G6	(IE1-)B.0R 56 G6	BZFM 0.25	3	-	-	BFK 458-06	4
0.18	IE3-B.2R 71 KY6	IE2-B.2R 71 K6	(IE1-)B.1R 71 K6	(IE1-)B.0R 63 K6	BZFM 0.25	3	-	-	BFK 458-06	4
0.18	IE3-B.2R 71 KY6	IE2-B.2R 71 K6	(IE1-)B.1R 71 K6	(IE1-)B.0R 63 K6	BZFM 0.63	6.3	-	-	-	-
0.25	IE3-B.1R 71 GY6	IE2-BE.R 71 G6	(IE1-)B.1R 71 G6	(IE1-)B.0R 63 G6	BZFM 0.25	3	-	-	BFK 458-06	4
0.25	IE3-B.1R 71 GY6	IE2-BE.R 71 G6	(IE1-)B.1R 71 G6	(IE1-)B.0R 63 G6	BZFM 0.63	6.3	-	-	-	-
0.37	IE3-B.1R 80 K6	IE2-B.2R 80 K6	(IE1-)B.1R 80 K6	(IE1-)B.0R 71 K6	BZFM 0.63	6.3	-	-	BFK 458-06	4
0.37	-	-	(IE1-)B.1R 80 K6	(IE1-)B.0R 71 K6	BZFM 1.6	13.5	-	-	BFK 458-08	8
0.55	IE3-B.1R 80 G6	IE2-B.1R 80 GY6	(IE1-)B.1R 80 G6	(IE1-)B.0R 71 G6	BZFM 0.63	6.3	-	-	BFK 458-06	4
0.55	-	-	(IE1-)B.1R 80 G6	(IE1-)B.0R 71 G6	BZFM 1.6	13.5	-	-	BFK 458-08	8
0.75	-	-	(IE1-)B.1R 90 S6	(IE1-)B.0R 80 K6	BZFM 1.6	13.5	-	-	BFK 458-06	4
0.75	-	-	(IE1-)B.1R 90 S6	(IE1-)B.0R 80 K6	-	-	-	-	BFK 458-08	8
0.75	IE3-B.1R 90 S6	IE2-B.1R 90 S6	(IE1-)B.1R 90 S6	(IE1-)B.0R 80 K6	BZFM 2.5	27	-	-	BFK 458-10	16
1.1	-	-	(IE1-)B.1R 90 L6	(IE1-)B.0R 80 G6	BZFM 1.6	13.5	-	-	BFK 458-06	4
1.1	-	-	(IE1-)B.1R 90 L6	(IE1-)B.0R 80 G6	-	-	-	-	BFK 458-08	8
1.1	IE3-B.1R 90 L6	IE2-B.1R 90 L6	(IE1-)B.1R 90 L6	(IE1-)B.0R 80 G6	BZFM 1.6	13.5	-	-	BFK 458-10	16
1.5	-	-	(IE1-)B.1R 100 L6	(IE1-)B.0R 90 L6	BZFM 2.5	27	-	-	BFK 458-08	8
1.5	-	-	(IE1-)B.1R 100 L6	(IE1-)B.0R 90 L6	-	-	-	-	BFK 458-10	16
2.2	IE3-B.1R 100 L6	IE2-B.1R 100 LX6	(IE1-)B.1R 100 L6	(IE1-)B.0R 90 L6	BZFM 4	37	-	-	BFK 458-12	32
2.2	-	-	(IE1-)B.1R 112 M6	(IE1-)B.0R 100 L6	BZFM 4	37	-	-	BFK 458-10	16
2.2	-	-	(IE1-)B.1R 112 M6	(IE1-)B.0R 100 L6	-	-	-	-	BFK 458-12	32
2.2	IE3-B.1R 112 MZ6	IE2-B.1R 112 MV6	(IE1-)B.1R 112 M6	(IE1-)B.0R 100 L6	BZFM 6.3	65	-	-	BFK 458-14	60
3.0	-	-	(IE1-)B.1R 132 S6T	(IE1-)B.0R 100 LX6	BZFM 4	37	-	-	BFK 458-12	32
3.0	-	IE2-B.1R 112 MZ6	(IE1-)B.1R 132 S6T	(IE1-)B.0R 100 LX6	BZFM 6.3	65	-	-	BFK 458-14	60
3.0	IE3-B.1R 132 S6	-	-	-	-	-	-	-	-	-
3.0	IE3-B.1R 132 S6	IE2-B.1R 132 S6	(IE1-)B.1R 132 S6	(IE1-)B.0R 112 M6	BZFM 6.3	65	-	-	BFK 458-14	60
4.0	IE3-B.1R 132 M6	-	(IE1-)B.1R 132 M6	(IE1-)B.0R 112 MX6	BZFM 10	100	-	-	BFK 458-16	80
4.0	-	IE2-B.1R 132 M6	-	-	BZFM 10	125	-	-	BFK 458-16	80
4.0	IE3-B.1R 132 M6	-	-	-	-	-	-	-	-	-
5.5	-	IE2-B.1R 132 MX6	(IE1-)B.1R 132 MX6	(IE1-)B.0R 132 S6	-	-	-	-	BFK 458-18	150
5.5	IE3-B.1R 132 MX6	-	-	-	-	-	-	-	-	-
5.5	IE3-B.1R 132 MX6	IE2-B.1R 132 MX6	(IE1-)B.1R 132 MX6	(IE1-)B.0R 132 S6	BZFM 10	125	-	-	-	-
7.5	-	IE2-B.2R 160 M6	(IE1-)B.1R 160 M6	(IE1-)B.0R 132 M6	-	-	NFF 10	100	-	-
7.5	IE3-B.1R 160 M6	-	-	-	-	-	-	-	-	-
7.5	IE3-B.1R 160 M6	IE2-B.2R 160 M6	(IE1-)B.1R 160 M6	(IE1-)B.0R 132 M6	BZFM 16	200	-	-	BFK 458-18	150
11.0	-	IE2-B.1R 160 L6	(IE1-)B.1R 160 L6	(IE1-)B.0R 160 S6	-	-	NFF 25	250	-	-
11.0	IE3-B.1R 160 L6C	-	-	-	-	-	-	-	-	-
11.0	IE3-B.1R 160 L6C	IE2-B.1R 160 L6	(IE1-)B.1R 160 L6	(IE1-)B.0R 160 S6	BZFM 16	250	-	-	BFK 458-20	260
15.0	-	IE2-B.2R 180 L6	(IE1-)B.1R 180 L6	(IE1-)B.0R 160 M6	-	-	NFF 25	250	-	-
15.0	IE3-B.1R 180 L6C	IE2-B.2R 180 L6	(IE1-)B.1R 180 L6	(IE1-)B.0R 160 M6	BZFM 25	380	-	-	BFK 458-20	260
18.5	-	IE2-B.1R 200 L6	(IE1-)B.1R 200 L6	(IE1-)B.0R 180 S6	-	-	NFF 40	400	-	-
18.5	IE3-B.1R 200 L6	-	-	-	-	-	-	-	-	-
18.5	IE3-B.1R 200 L6	IE2-B.1R 200 L6	(IE1-)B.1R 200 L6	(IE1-)B.0R 180 S6	BZFM 25	380	-	-	BFK 458-25	400
22.0	-	(IE1-)B.1R 200 LX6	(IE1-)B.1R 200 LX6	(IE1-)B.0R 180 M6	-	-	-	-	-	-
22.0	-	IE2-B.2R 200 LX6	-	-	-	-	-	-	-	-
22.0	-	IE2-B.2R 200 LX6	(IE1-)B.1R 200 LX6	(IE1-)B.0R 180 M6	-	-	NFF 40	400	-	-
22.0	IE3-B.1R 200 LX6C	-	-	-	-	-	-	-	-	-
22.0	IE3-B.1R 200 LX6C	IE2-B.2R 200 LX6	(IE1-)B.1R 200 LX6	(IE1-)B.0R 180 M6	BZFM 25	380	-	-	BFK 458-25	400
30.0	-	(IE1-)B.1R 225 M6	(IE1-)B.1R 225 M6	(IE1-)B.0R 200 M6	-	-	-	-	-	-
30.0	-	IE2-BE2R 225 M6	-	-	BZFM 25	380	NFF 40	400	BFK 458-25	400
30.0	IE3-B.1R 225 M6	-	-	-	4BZFM 63	630	-	-	BFK 458-25	400
37.0	-	(IE1-)B.1R 250 M6	(IE1-)B.1R 250 M6	(IE1-)B.0R 225 M6	-	-	-	-	-	-
37.0	-	IE2-B.2R 250 M6	-	-	-	-	-	-	-	-
37.0	IE3-B.1R 250 M6	-	-	-	-	-	-	-	-	-
37.0	-	IE2-B.2R 250 M6	(IE1-)B.1R 250 M6	(IE1-)B.0R 225 M6	-	-	-	-	-	-
37.0	IE3-B.1R 250 M6	IE2-B.2R 250 M6	(IE1-)B.1R 250 M6	(IE1-)B.0R 225 M6	4BZFM 63	630	-	-	BFK 458-25	400
45.0	-	IE2-B.1R 280 S6	(IE1-)B.1R 280 S6	(IE1-)B.0R 250 S6	-	-	NFF 100	1000	-	-
45.0	IE3-B.1R 280 S6	-	-	-	-	-	-	-	-	-
45.0	IE3-B.1R 280 S6	IE2-B.1R 280 S6	(IE1-)B.1R 280 S6	(IE1-)B.0R 250 S6	4BZFM 100	1000	-	-	BFK 458-25	400
55.0	-	(IE1-)B.1R 280 M6	(IE1-)B.1R 280 M6	(IE1-)B.0R 250 M6	-	-	-	-	-	-
55.0	-	IE2-B.1R 280 M6	(IE1-)B.1R 280 M6	(IE1-)B.0R 250 M6	-	-	NFF 100	1000	-	-
55.0	IE3-B.1R 280 M6	IE2-B.1R 280 M6	-	-	-	-	-	-	-	-
55.0	IE3-B.1R 280 M6	IE2-B.1R 280 M6	(IE1-)B.1R 280 M6	(IE1-)B.0R 250 M6	4BZFM 100	1000	-	-	BFK 458-25	400

6-pole Brake motors Built-on brake with squirrel-cage rotor; Stromag, Intorq brake

Premium Efficiency IE3/High Efficiency IE2/Standard Efficiency IE1 according to IEC/EN 60034-30-1

P_B P_B KW	For motor IE3-	For motor IE2-	For motor (IE1-)B.1R	For motor (IE1-)B.0R	Stromag BZFM	Nm	Stromag NFF	Nm	Intorq BFK	Nm
75.0	-	IE2-B.1R 315 S6	(IE1-)B.1R 315 S6	(IE1-)B.0R 280 S6	-	-	NFF 160	1600	-	-
75.0	IE3-B.1R 315 S6	-	-	-	-	-	-	-	-	-
75.0	IE3-B.1R 315 S6	IE2-B.1R 315 S6	(IE1-)B.1R 315 S6	(IE1-)B.0R 280 S6	4BZFM 100	1000	-	-	-	-
90.0	-	IE2-B.1R 315 M6	(IE1-)B.1R 315 M6	(IE1-)B.0R 280 M6	4BZFM 100	1000	NFF 160	1600	-	-
90.0	IE3-B.1R 315 M6	-	-	-	4BZFM 160	1600	-	-	-	-
110.0	-	IE2-B.1R 315 MX6	(IE1-)B.1R 315 MX6	(IE1-)B.0R 315 S6	4BZFM 100	1000	NFF 160	1600	-	-
110.0	IE3-B.1R 315 MX6	-	-	-	4BZFM 160	1600	-	-	-	-
132.0	-	IE2-B.1R 315 MY6	(IE1-)B.1R 315 MY6	(IE1-)B.0R 315 M6	4BZFM 160	1600	NFF 250	2500	-	-
160.0	-	IE2-B.1R 315 L6	(IE1-)B.1R 315 L6	(IE1-)B.0R 315 L6	-	-	NFF 250	2500	-	-
160.0	IE3-B.1R 315 L6	-	-	-	-	-	-	-	-	-
160.0	IE3-B.41R 315 L6	IE2-B.1R 315 L6	(IE1-)B.1R 315 L6	(IE1-)B.0R 315 L6	4BZFM 160	1600	-	-	-	-
200.0	-	-	(IE1-)B.1R 315 LX6	(IE1-)B.0R 315 LX6	4BZFM 160	1600	NFF 250	2500	-	-
200.0	-	IE2-B.1R 315 LX6	(IE1-)B.1R 315 LX6	(IE1-)B.0R 315 LX6	-	-	-	-	-	-
250.0	-	IE2-B.2R 355 M6	(IE1-)B.2R 355 M6	-	-	-	NFF 400	4000	-	-
250.0	IE3-B.1R 355 M6	-	-	-	-	-	-	-	-	-
250.0	IE3-B.1R 355 M6	IE2-B.2R 355 M6	(IE1-)B.2R 355 M6	-	4BZFM 160	1600	-	-	-	-
315.0	-	-	(IE1-)B.2R 355 MX6	-	-	-	-	-	-	-
315.0	IE3-B.2R 355 MX6	-	-	-	-	-	-	-	-	-
315.0	-	IE2-B.2R 355 MX6	(IE1-)B.2R 355 MX6	-	-	-	NFF 400	4000	-	-
315.0	IE3-B.2R 355 MX6	IE2-B.2R 355 MX6	(IE1-)B.2R 355 MX6	-	4BZFM 250	2500	-	-	-	-
250.0	IE3-B.2R 355 L6	-	-	-	4BZFM 250	2500	NFF 400	4000	-	-
315.0	IE3-B.2R 355 LX6	-	-	-	4BZFM 250	2500	NFF 400	4000	-	-
355.0	IE3-B.2R 400 MY6	-	-	-	-	-	***)	-	-	-
400.0	IE3-B.2R 400 M6	-	-	-	-	-	***)	-	-	-
450.0	IE3-B.2R 400 MX6	-	-	-	-	-	***)	-	-	-
500.0	IE3-B.2R 400 L6	-	-	-	-	-	***)	-	-	-

Corresponding basic version plus brake and brake mounting (see Extra price list)

Sizes 56–132 T plus rectifier (see Brake accessories)

(IE1-) can be supplied with and without marking of IE classification

***) upon request

6-pole Brake motors

Built-on brake with squirrel-cage rotor; Mayr, Pintsch-Bubenzler, Precima brake

Premium Efficiency IE3/High Efficiency IE2/Standard Efficiency IE1 according to IEC/EN 60034-30-1

P _B P _B KW	For motor IE3-	For motor IE2-	For motor (IE1-)B.1R	For motor (IE1-)B.0R	Mayr M 800/891 (IP 65)	Nm	Pintsch-Bubenzler KFB/SFB	Nm	Precima FDB	Nm
0.09	-	-	(IE1-)B.1R 63 K6	(IE1-)B.0R 56 K6	M2/891.	4	-	-	***	***
0.12	IE3-B.1R 63 G6	IE2-B.2R 63 G6	(IE1-)B.1R 63 G6	(IE1-)B.0R 56 G6	M2/891.	4	-	-	***	***
0.18	IE3-B.2R 71 KY6	IE2-B.2R 71 K6	(IE1-)B.1R 71 K6	(IE1-)B.0R 63 K6	-	-	-	-	***	***
0.18	IE3-B.2R 71 KY6	IE2-B.2R 71 K6	(IE1-)B.1R 71 K6	(IE1-)B.0R 63 K6	M2/891.	4	-	-	***	***
0.25	IE3-B.1R 71 GY6	IE2-BE.R 71 G6	(IE1-)B.1R 71 G6	(IE1-)B.0R 63 G6	-	-	-	-	***	***
0.25	IE3-B.1R 71 GY6	IE2-BE.R 71 G6	(IE1-)B.1R 71 G6	(IE1-)B.0R 63 G6	M4/891.	4	-	-	***	***
0.37	IE3-B.1R 80 K6	IE2-B.2R 80 K6	(IE1-)B.1R 80 K6	(IE1-)B.0R 71 K6	-	-	-	-	***	***
0.37	-	-	(IE1-)B.1R 80 K6	(IE1-)B.0R 71 K6	M8/891.	8	-	-	***	***
0.55	IE3-B.1R 80 G6	IE2-B.1R 80 GY6	(IE1-)B.1R 80 G6	(IE1-)B.0R 71 G6	-	-	-	-	***	***
0.55	-	-	(IE1-)B.1R 80 G6	(IE1-)B.0R 71 G6	M8/891.	8	-	-	***	***
0.75	-	-	(IE1-)B.1R 90 S6	(IE1-)B.0R 80 K6	-	-	-	-	***	***
0.75	-	-	(IE1-)B.1R 90 S6	(IE1-)B.0R 80 K6	-	-	-	-	***	***
0.75	IE3-B.1R 90 S6	IE2-B.1R 90 S6	(IE1-)B.1R 90 S6	(IE1-)B.0R 80 K6	M16/891.	16	-	-	***	***
1.1	-	-	(IE1-)B.1R 90 L6	(IE1-)B.0R 80 G6	-	-	-	-	***	***
1.1	-	-	(IE1-)B.1R 90 L6	(IE1-)B.0R 80 G6	-	-	-	-	***	***
1.1	IE3-B.1R 90 L6	IE2-B.1R 90 L6	(IE1-)B.1R 90 L6	(IE1-)B.0R 80 G6	M16/891.	16	-	-	***	***
1.5	-	-	(IE1-)B.1R 100 L6	(IE1-)B.0R 90 L6	-	-	-	-	***	***
1.5	-	-	(IE1-)B.1R 100 L6	(IE1-)B.0R 90 L6	-	-	-	-	***	***
2.2	IE3-B.1R 100 L6	IE2-B.1R 100 LX6	(IE1-)B.1R 100 L6	(IE1-)B.0R 90 L6	M32/891.	32	-	-	***	***
2.2	-	-	(IE1-)B.1R 112 M6	(IE1-)B.0R 100 L6	-	-	-	-	***	***
2.2	-	-	(IE1-)B.1R 112 M6	(IE1-)B.0R 100 L6	-	-	-	-	***	***
2.2	IE3-B.1R 112 MZ6	IE2-B.1R 112 MV6	(IE1-)B.1R 112 M6	(IE1-)B.0R 100 L6	M60/891.	60	-	-	***	***
3.0	-	-	(IE1-)B.1R 132 S6T	(IE1-)B.0R 100 LX6	-	-	-	-	***	***
3.0	-	IE2-B.1R 112 MZ6	(IE1-)B.1R 132 S6T	(IE1-)B.0R 100 LX6	M60/891.	60	-	-	***	***
3.0	IE3-B.1R 132 S6	-	-	-	-	-	-	-	-	-
3.0	IE3-B.1R 132 S6	IE2-B.1R 132 S6	(IE1-)B.1R 132 S6	(IE1-)B.0R 112 M6	M32/891.010.1	64	-	-	FDB 17	60
4.0	IE3-B.1R 132 M6	-	(IE1-)B.1R 132 M6	(IE1-)B.0R 112 MX6	M60/891.100.1	100	-	-	FDB 20	100
4.0	-	IE2-B.1R 132 M6	-	-	M60/891.100.1	100	-	-	FDB 20	100
4.0	IE3-B.1R 132 M6	-	-	-	-	-	-	-	-	-
5.5	-	IE2-B.1R 132 MX6	(IE1-)B.1R 132 MX6	(IE1-)B.0R 132 S6	-	-	-	-	FDB 23	150
5.5	IE3-B.1R 132 MX6	-	-	-	-	-	-	-	-	-
5.5	IE3-B.1R 132 MX6	IE2-B.1R 132 MX6	(IE1-)B.1R 132 MX6	(IE1-)B.0R 132 S6	M32/891.010.1	100	KFB 10	100	-	-
7.5	-	IE2-B.2R 160 M6	(IE1-)B.1R 160 M6	(IE1-)B.0R 132 M6	-	-	KFB 10	100	-	-
7.5	IE3-B.1R 160 M6	-	-	-	M32/891.010.1	100	KFB 30	175	-	-
7.5	IE3-B.1R 160 M6	IE2-B.2R 160 M6	(IE1-)B.1R 160 M6	(IE1-)B.0R 132 M6	M100/891.100.1	180	-	-	FDB 23	150
11.0	-	IE2-B.1R 160 L6	(IE1-)B.1R 160 L6	(IE1-)B.0R 160 S6	-	-	-	-	-	-
11.0	IE3-B.1R 160 L6C	-	-	-	-	-	-	-	-	-
11.0	IE3-B.1R 160 L6C	IE2-B.1R 160 L6	(IE1-)B.1R 160 L6	(IE1-)B.0R 160 S6	M150/891.100.1	250	KFB 30	300	FDB 26	250
15.0	-	IE2-B.2R 180 L6	(IE1-)B.1R 180 L6	(IE1-)B.0R 160 M6	-	-	KFB 30	300	-	-
15.0	IE3-B.1R 180 L6C	IE2-B.2R 180 L6	(IE1-)B.1R 180 L6	(IE1-)B.0R 160 M6	M250/891.100.1	310	KFB 30	300	FDB 26	250
18.5	-	IE2-B.1R 200 L6	(IE1-)B.1R 200 L6	(IE1-)B.0R 180 S6	-	-	-	-	-	-
18.5	IE3-B.1R 200 L6	-	-	-	-	-	-	-	-	-
18.5	IE3-B.1R 200 L6	IE2-B.1R 200 L6	(IE1-)B.1R 200 L6	(IE1-)B.0R 180 S6	M250/891.100.1	450	KFB 40	400	FDB 30	400
22.0	-	(IE1-)B.1R 200 LX6	(IE1-)B.1R 200 LX6	(IE1-)B.0R 180 M6	-	-	KFB 40	400	-	-
22.0	-	IE2-B.2R 200 LX6	-	-	-	-	KFB 40/70	470	-	-
22.0	-	IE2-B.2R 200 LX6	(IE1-)B.1R 200 LX6	(IE1-)B.0R 180 M6	-	-	-	-	-	-
22.0	IE3-B.1R 200 LX6C	-	-	-	-	-	KFB 40	470	-	-
22.0	IE3-B.1R 200 LX6C	IE2-B.2R 200 LX6	(IE1-)B.1R 200 LX6	(IE1-)B.0R 180 M6	M250/891.100.1	450	-	-	FDB 30	400
30.0	-	(IE1-)B.1R 225 M6	(IE1-)B.1R 225 M6	(IE1-)B.0R 200 M6	-	-	-	-	-	-
30.0	-	IE2-BE2R 225 M6	-	-	M500/891.100.1	500	KFB 63	630	FDB 30	400
30.0	IE3-B.1R 225 M6	-	-	-	M500/891.100.1	500	KFB 63	630	FDB 30	400
37.0	-	-	(IE1-)B.1R 250 M6	(IE1-)B.0R 225 M6	-	-	-	-	-	-
37.0	-	IE2-B.2R 250 M6	-	-	-	-	-	-	-	-
37.0	IE3-B.1R 250 M6	-	-	-	-	-	KFB 63	820	-	-
37.0	-	IE2-B.2R 250 M6	(IE1-)B.1R 250 M6	(IE1-)B.0R 225 M6	-	-	-	-	-	-
37.0	IE3-B.1R 250 M6	IE2-B.2R 250 M6	(IE1-)B.1R 250 M6	(IE1-)B.0R 225 M6	M500/891.100.1	500	-	-	FDB 30	400
45.0	-	IE2-B.1R 280 S6	(IE1-)B.1R 280 S6	(IE1-)B.0R 250 S6	M500/891.100.1	500	-	-	-	-
45.0	IE3-B.1R 280 S6	-	-	-	M1000/891.010.1	500	-	-	-	-
45.0	IE3-B.1R 280 S6	IE2-B.1R 280 S6	(IE1-)B.1R 280 S6	(IE1-)B.0R 250 S6	-	-	KFB 100	1000	FDB 30	400
55.0	-	-	(IE1-)B.1R 280 M6	(IE1-)B.0R 250 M6	M500/891.100.1	560	-	-	-	-
55.0	-	IE2-B.1R 280 M6	(IE1-)B.1R 280 M6	(IE1-)B.0R 250 M6	-	-	-	-	-	-
55.0	IE3-B.1R 280 M6	IE2-B.1R 280 M6	-	-	M1000/891.010.1	560	-	-	-	-
55.0	IE3-B.1R 280 M6	IE2-B.1R 280 M6	(IE1-)B.1R 280 M6	(IE1-)B.0R 250 M6	-	-	KFB 100	1000	FDB 30	400

6-pole Brake motors Built-on brake with squirrel-cage rotor; Mayr, Pintsch-Bubenzler, Precima brake

Premium Efficiency IE3/High Efficiency IE2/Standard Efficiency IE1 according to IEC/EN 60034-30-1

P _B P _B KW	For motor IE3-	For motor IE2-	For motor (IE1-)B.1R	For motor (IE1-)B.0R	Mayr M 800/891 (IP65)	Nm	Pintsch-Bubenzler KFB/SFB	Nm	Precima FDB	Nm
75.0	-	IE2-B.1R 315 S6	(IE1-)B.1R 315 S6	(IE1-)B.0R 280 S6	-	-	-	-	-	-
75.0	IE3-B.1R 315 S6	-	-	-	M1000/891.010.1	800	-	-	-	-
75.0	IE3-B.1R 315 S6	IE2-B.1R 315 S6	(IE1-)B.1R 315 S6	(IE1-)B.0R 280 S6	-	-	KFB 160	1600	-	-
90.0	-	IE2-B.1R 315 M6	(IE1-)B.1R 315 M6	(IE1-)B.0R 280 M6	-	-	KFB 160	1600	-	-
90.0	IE3-B.1R 315 M6	-	-	-	-	-	KFB 160	1600	-	-
110.0	-	IE2-B.1R 315 MX6	(IE1-)B.1R 315 MX6	(IE1-)B.0R 315 S6	-	-	KFB 160	1600	-	-
110.0	IE3-B.1R 315 MX6	-	-	-	-	-	KFB 160	1600	-	-
132.0	-	IE2-B.1R 315 MY6	(IE1-)B.1R 315 MY6	(IE1-)B.0R 315 M6	-	-	SFB 250	2500	-	-
160.0	-	IE2-B.1R 315 L6	(IE1-)B.1R 315 L6	(IE1-)B.0R 315 L6	-	-	SFB 250	2500	-	-
160.0	IE3-B.1R 315 L6	-	-	-	-	-	KFB 160	1600	-	-
160.0	IE3-B.41R 315 L6	IE2-B.1R 315 L6	(IE1-)B.1R 315 L6	(IE1-)B.0R 315 L6	-	-	-	-	-	-
200.0	-	-	(IE1-)B.1R 315 LX6	(IE1-)B.0R 315 LX6	-	-	-	-	-	-
200.0	-	IE2-B.1R 315 LX6	(IE1-)B.1R 315 LX6	(IE1-)B.0R 315 LX6	-	-	SFB 250	2500	-	-
250.0	-	IE2-B.2R 355 M6	(IE1-)B.2R 355 M6	-	-	-	SFB 250/330	3300	-	-
250.0	IE3-B.1R 355 M6	-	-	-	-	-	KFB 160	1600	-	-
250.0	IE3-B.1R 355 M6	IE2-B.2R 355 M6	(IE1-)B.2R 355 M6	-	-	-	-	-	-	-
315.0	-	-	(IE1-)B.2R 355 MX6	-	-	-	SFB 250/330	3300	-	-
315.0	IE3-B.2R 355 MX6	-	-	-	-	-	SFB 250	2500	-	-
315.0	-	IE2-B.2R 355 MX6	(IE1-)B.2R 355 MX6	-	-	-	-	-	-	-
315.0	IE3-B.2R 355 MX6	IE2-B.2R 355 MX6	(IE1-)B.2R 355 MX6	-	-	-	-	-	-	-
250.0	IE3-B.2R 355 L6	-	-	-	-	-	SFB 250	2500	-	-
315.0	IE3-B.2R 355 LX6	-	-	-	-	-	SFB 250	2500	-	-
355.0	IE3-B.2R 400 MY6	-	-	-	-	-	***)	-	-	-
400.0	IE3-B.2R 400 M6	-	-	-	-	-	***)	-	-	-
450.0	IE3-B.2R 400 MX6	-	-	-	-	-	***)	-	-	-
500.0	IE3-B.2R 400 L6	-	-	-	-	-	***)	-	-	-

Corresponding basic version plus brake and brake mounting (see Extra price list)

Sizes 56–132 T plus rectifier (see Brake accessories)

(IE1-) can be supplied with and without marking of IE classification

***) upon request

Brake assignments

8-pole Brake motors Built-on brake with squirrel-cage rotor; Stromag, Intorq brake

Premium Efficiency IE3/High Efficiency IE2/Standard Efficiency IE1 according to IEC/EN 60034-30-1

P _B P _B KW	For motor IE3-	For motor IE2-	For motor (IE1-)B.1R	For motor (IE1-)B.0R	Stromag BZFM	Nm	Stromag NFF	Nm	Intorq BFK	Nm
0.09	-	-	(IE1-)B.1R 71 K8	(IE1-)B.0R 63 K8	BZFM 0.25	3	-	-	-	-
0.09	-	-	(IE1-)B.1R 71 K8	(IE1-)B.0R 63 K8	BZFM 0.63	6.3	-	-	BFK 458-06	4
0.12	-	-	(IE1-)B.1R 71 G8	(IE1-)B.0R 63 G8	BZFM 0.25	3	-	-	-	-
0.12	IE3-B.1R 71 G8	IE2-B.2R 71 G8	(IE1-)B.1R 71 G8	(IE1-)B.0R 63 G8	BZFM 0.63	6.3	-	-	BFK 458-06	4
0.18	-	-	(IE1-)B.1R 80 K8	(IE1-)B.0R 71 K8	BZFM 0.63	6.3	-	-	BFK 458-06	4
0.18	IE3-B.2R 80 K8	IE2-B.2R 80 K8	(IE1-)B.1R 80 K8	(IE1-)B.0R 71 K8	BZFM 1.6	13.5	-	-	BFK 458-08	8
0.25	-	-	(IE1-)B.1R 80 G8	(IE1-)B.0R 71 G8	BZFM 0.63	6.3	-	-	BFK 458-06	4
0.25	IE3-B.1R 80 G8	IE2-B.2R 80 G8	(IE1-)B.1R 80 G8	(IE1-)B.0R 71 G8	BZFM 1.6	13.5	-	-	BFK 458-08	8
0.37	-	-	(IE1-)B.1R 90 S8	(IE1-)B.0R 80 K8	BZFM 1.6	13.5	-	-	BFK 458-06	4
0.37	IE3-B.2R 90 S8	IE2-B.2R 90 S8	(IE1-)B.1R 90 S8	(IE1-)B.0R 80 K8	BZFM 2.5	27	-	-	BFK 458-08	8
0.37	-	-	(IE1-)B.1R 90 S8	(IE1-)B.0R 80 K8	-	-	-	-	BFK 458-10	16
0.55	-	-	(IE1-)B.1R 90 L8	(IE1-)B.0R 80 G8	BZFM 1.6	13.5	-	-	BFK 458-06	4
0.55	-	-	(IE1-)B.1R 90 L8	(IE1-)B.0R 80 G8	-	-	-	-	BFK 458-08	8
0.55	IE3-B.1R 90 L8	IE2-B.2R 90 L8	(IE1-)B.1R 90 L8	(IE1-)B.0R 80 G8	BZFM 2.5	27	-	-	BFK 458-10	16
0.75	-	-	(IE1-)B.1R 100 L8	(IE1-)B.0R 90 L8	BZFM 2.5	27	-	-	BFK 458-08	8
0.75	-	-	(IE1-)B.1R 100 L8	(IE1-)B.0R 90 L8	-	-	-	-	BFK 458-10	16
0.75	IE3-B.1R 100 L8	IE2-B.1R 100 L8	(IE1-)B.1R 100 L8	(IE1-)B.0R 90 L8	BZFM 4	37	-	-	BFK 458-12	32
1.1	-	-	(IE1-)B.1R 100 LX8	(IE1-)B.0R 100 S8	BZFM 4	37	-	-	BFK 458-10	16
1.1	-	-	(IE1-)B.1R 100 LX8	(IE1-)B.0R 100 S8	-	-	-	-	BFK 458-12	32
1.1	IE3-B.1R 100 LX8	IE2-B.1R 100 LX8	(IE1-)B.1R 100 LX8	(IE1-)B.0R 100 S8	BZFM 6.3	65	-	-	BFK 458-14	60
1.5	-	-	(IE1-)B.1R 112 M8	(IE1-)B.0R 100 L8	BZFM 4	37	-	-	BFK 458-10	16
1.5	-	-	(IE1-)B.1R 112 M8	(IE1-)B.0R 100 L8	-	-	-	-	BFK 458-12	32
1.5	IE3-B.1R 112 MZ8	IE2-B.1R 112 MV8	(IE1-)B.1R 112 M8	(IE1-)B.0R 100 L8	BZFM 6.3	65	-	-	BFK 458-14	60
2.2	-	-	(IE1-)B.1R 132 S8T	(IE1-)B.0R 100 LX8	BZFM 4	37	-	-	BFK 458-12	32
2.2	-	-	(IE1-)B.1R 132 S8T	(IE1-)B.0R 100 LX8	BZFM 6.3	65	-	-	BFK 458-14	60
2.2	-	-	(IE1-)B.1R 132 S8	(IE1-)B.0R 112 M8	-	-	-	-	BFK 458-14	60
2.2	-	IE2-B.1R 132 S8	(IE1-)B.1R 132 S8	(IE1-)B.0R 112 M8	BZFM 6.3	65	-	-	-	-
2.2	IE3-B.1R 132 S8	-	-	-	BZFM 10	100	-	-	BFK 458-14	60
3.0	-	-	(IE1-)B.1R 132 M8	(IE1-)B.0R 112 MX8	-	-	-	-	BFK 458-16	80
3.0	IE3-B.1R 132 M8	-	-	-	-	-	-	-	BFK 458-16	80
3.0	IE3-B.1R 132 M8	IE2-B.1R 132 M8	(IE1-)B.1R 132 M8	(IE1-)B.0R 112 MX8	BZFM 10	100	-	-	-	-
4.0	-	-	(IE1-)B.1R 160 M8	(IE1-)B.1R 160 M8	-	-	-	-	BFK 458-18	150
4.0	-	IE2-B.1R 160 M8	(IE1-)B.1R 160 M8	-	-	-	-	-	-	-
4.0	IE3-B.1R 160 M8	-	-	-	-	-	-	-	BFK 458-16	125
4.0	IE3-B.1R 160 M8	IE2-B.1R 160 M8	(IE1-)B.1R 160 M8	(IE1-)B.0R 132 S8	BZFM 10	125	-	-	-	-
5.5	-	-	(IE1-)B.1R 160 MX8	(IE1-)B.0R 132 M8	-	-	NFF 10	100	BFK 458-18	150
5.5	IE3-B.1R 160 MX8	-	-	-	-	-	-	-	BFK 458-18	150
5.5	IE3-B.1R 160 MX8	IE2-B.2R 160 MX8	(IE1-)B.1R 160 MX8	(IE1-)B.0R 132 M8	BZFM 16	200	-	-	-	-
7.5	-	-	(IE1-)B.1R 160 L8	(IE1-)B.0R 160 S8	-	-	NFF 25	250	BFK 458-20	260
7.5	IE3-B.1R 160 L8	-	-	-	-	-	-	-	BFK 458-20	260
7.5	IE3-B.1R 160 L8	IE2-B.1R 160 L8	(IE1-)B.1R 160 L8	(IE1-)B.0R 160 S8	BZFM 16	250	-	-	-	-
11.0	-	-	(IE1-)B.1R 180 L8	(IE1-)B.0R 160 M8	-	-	NFF 25	250	BFK 458-20	260
11.0	IE3-B.1R 180 L8	-	-	-	-	-	-	-	BFK 458-20	290
11.0	IE3-B.1R 180 L8	IE2-B.2R 180 L8	(IE1-)B.1R 180 L8	(IE1-)B.0R 160 M8	BZFM 25	380	-	-	-	-
15.0	-	-	(IE1-)B.1R 200 L8	(IE1-)B.0R 180 S8	-	-	NFF 40	400	BFK 458-25	400
15.0	IE3-B.1R 200 L8	-	-	-	-	-	-	-	BFK 458-25	400
15.0	IE3-B.1R 200 L8	IE2-B.1R 200 L8	(IE1-)B.1R 200 L8	(IE1-)B.0R 180 S8	BZFM 25	380	-	-	-	-
18.5	-	-	(IE1-)B.1R 225 S8	(IE1-)B.1R 225 S8	-	-	NFF 63	630	BFK 458-25	400
18.5	IE3-B.1R 225 S8	-	-	-	-	-	-	-	BFK 458-25	490
18.5	IE3-B.1R 225 S8	IE2-B.2R 225 S8	(IE1-)B.1R 225 S8	-	BZFM 25	380	-	-	-	-
18.5	-	-	-	(IE1-)B.0R 180 M8	BZFM 25	380	-	-	-	-
22.0	-	-	(IE1-)B.1R 225 M8	(IE1-)B.0R 200 M8	BZFM 25	380	NFF 63	630	BFK 458-25	400
22.0	IE3-B.1R 225 M8	-	-	-	-	-	-	-	BFK 458-25	600
22.0	IE3-B.1R 225 M8	IE3-B.2R 225 M8	-	-	4BZFM 63	630	-	-	-	-
30.0	-	-	(IE1-)B.1R 250 M8	(IE1-)B.0R 225 M8	-	-	NFF 63	630	BFK 458-25	400
30.0	IE3-B.1R 250 M8	-	-	-	-	-	NFF 100	1000	BFK 458-25	400
30.0	IE3-B.1R 250 M8	IE2-B.1R 250 M8	(IE1-)B.1R 250 M8	(IE1-)B.0R 225 M8	4BZFM 63	800	-	-	-	-
37.0	-	-	(IE1-)B.1R 280 S8	(IE1-)B.0R 250 S8	-	-	-	-	BFK 458-25	400
37.0	IE3-B.1R 280 S8	-	(IE1-)B.1R 280 S8	(IE1-)B.0R 250 S8	-	-	NFF 100	1000	-	-
37.0	IE3-B.1R 280 S8	IE2-B.1R 280 S8	(IE1-)B.1R 280 S8	(IE1-)B.0R 250 S8	4BZFM 100	1000	-	-	-	-
45.0	-	-	(IE1-)B.1R 280 M8	(IE1-)B.0R 250 M8	-	-	-	-	-	-
45.0	IE3-B.1R 280 M8	-	(IE1-)B.1R 280 M8	(IE1-)B.0R 250 M8	-	-	NFF 100	1000	-	-
45.0	IE3-B.1R 280 M8	IE2-B.1R 280 M8	(IE1-)B.1R 280 M8	(IE1-)B.0R 250 M8	4BZFM 100	1000	-	-	-	-

8-pole Brake motors Built-on brake with squirrel-cage rotor; Stromag, Intorq brake

Premium Efficiency IE3/High Efficiency IE2/Standard Efficiency IE1 according to IEC/EN 60034-30-1

P_B P_B KW	For motor IE3-	For motor IE2-	For motor (IE1-)B.1R	For motor (IE1-)B.0R	Stromag BZFM	Nm	Stromag NFF	Nm	Intorq BFK	Nm
55.0	-	-	(IE1-)B.1R 315 S8	(IE1-)B.0R 280 S8	-	-	NFF 160	1600	-	-
55.0	IE3-B.2R 315 S8	-	-	-	-	-	NFF 100	1000	-	-
55.0	IE3-B.2R 315 S8	IE2-B.1R 315 S8	(IE1-)B.1R 315 S8	(IE1-)B.0R 280 S8	4BZFM 100	1000	-	-	-	-
75.0	-	IE2-B.1R 315 M8	(IE1-)B.1R 315 M8	(IE1-)B.0R 280 M8	4BZFM 100	1000	-	-	-	-
75.0	IE3-B.1R 315 M8	-	(IE1-)B.1R 315 M8	(IE1-)B.0R 280 M8	-	-	NFF 160	1600	-	-
75.0	IE3-B.1R 315 M8	-	-	-	4BZFM 160	1600	-	-	-	-
90.0	-	IE2-B.1R 315 MX8	(IE1-)B.1R 315 MX8	(IE1-)B.0R 315 S8	4BZFM 100	1000	-	-	-	-
90.0	IE3-B.1R 315 MX8	-	(IE1-)B.1R 315 MX8	(IE1-)B.0R 315 S8	-	-	NFF 160	1600	-	-
90.0	IE3-B.1R 315 MX8	-	-	-	4BZFM 160	1600	-	-	-	-
110.0	-	-	(IE1-)B.1R 315 MY8	(IE1-)B.0R 315 M8	-	-	NFF 250	2500	-	-
110.0	IE3-B.1R 315 MY8	IE2-B.1R 315 MY8	(IE1-)B.1R 315 MY8	(IE1-)B.0R 315 M8	4BZFM 160	1600	-	-	-	-
132.0	-	-	(IE1-)B.1R 315 L8	(IE1-)B.0R 315 L8	-	-	NFF 250	2500	-	-
132.0	IE3-B.1R 315 L8	-	-	-	-	-	NFF 160	1600	-	-
132.0	IE3-B.1R 315 L8	IE2-B.1R 315 L8	(IE1-)B.1R 315 L8	(IE1-)B.0R 315 L8	4BZFM 160	1600	-	-	-	-
160.0	-	-	(IE1-)B.1R 315 LX8	(IE1-)B.0R 315 LX8	-	-	NFF 250	2500	-	-
160.0	-	IE2-B.1R 315 LX8	(IE1-)B.1R 315 LX8	(IE1-)B.0R 315 LX8	4BZFM 160	1600	-	-	-	-
160.0	-	-	(IE1-)B.2R 355 MY8	-	-	-	NFF 250	2500	-	-
160.0	IE3-B.1R 355 MY8	IE2-B.2R 355 MY8	(IE1-)B.2R 355 MY8	-	4BZFM 160	1600	-	-	-	-
200.0	-	-	(IE1-)B.2R 355 M8	-	-	-	NFF 250	2500	-	-
200.0	IE3-B.1R 355 M8	-	-	-	-	-	NFF 160	1600	-	-
200.0	IE3-B.1R 355 M8	IE2-B.2R 355 M8	(IE1-)B.2R 355 M8	-	4BZFM 160	1600	-	-	-	-
250.0	-	-	(IE1-)B.2R 355 MX8	-	-	-	NFF 250	2500	-	-
250.0	-	IE2-B.2R 355 MX8	(IE1-)B.2R 355 MX8	-	4BZFM 160	1600	-	-	-	-
250.0	IE3-B.2R 355 MX8	-	-	-	4BZFM 250	2500	NFF 160	1600	-	-
280.0	-	-	(IE1-)B.2R 355 LY8	-	-	-	NFF 250	2500	-	-
280.0	-	IE2-B.2R 355 LY8	(IE1-)B.2R 355 LY8	-	4BZFM 160	1600	-	-	-	-
315.0	IE3-B.2R 400 MY8	-	-	-	-	-	***)	-	-	-
355.0	IE3-B.2R 400 M8	-	-	-	-	-	***)	-	-	-
400.0	IE3-B.2R 400 MX8	-	-	-	-	-	***)	-	-	-
450.0	IE3-B.2R 400 L8	-	-	-	-	-	***)	-	-	-

Corresponding basic version plus brake and brake mounting (see Extra price list)

Sizes 56–132 T plus rectifier (see Brake accessories)

(IE1-) can be supplied with and without marking of IE classification

***) upon request

8-pole Brake motors

Built-on brake with squirrel-cage rotor; Mayr, Pintsch-Bubenzler, Precima brake

Premium Efficiency IE3/High Efficiency IE2/Standard Efficiency IE1 according to IEC/EN 60034-30-1

P _B P _B KW	For motor IE3-	For motor IE2-	For motor (IE1-)B.1R	For motor (IE1-)B.0R	Mayr M 800/891 (IP65)	Nm	Pintsch-Bubenzler KFB/SFB	Nm	Precima FDB	Nm
0.09	-	-	(IE1-)B.1R 71 K8	(IE1-)B.0R 63 K8	-	-	-	-	***	***
0.09	-	-	(IE1-)B.1R 71 K8	(IE1-)B.0R 63 K8	M2/891.	4	-	-	***	***
0.12	-	-	(IE1-)B.1R 71 G8	(IE1-)B.0R 63 G8	-	-	-	-	***	***
0.12	IE3-B.1R 71 G8	IE2-B.2R 71 G8	(IE1-)B.1R 71 G8	(IE1-)B.0R 63 G8	M2/891.	4	-	-	***	***
0.18	-	-	(IE1-)B.1R 80 K8	(IE1-)B.0R 71 K8	-	-	-	-	***	***
0.18	IE3-B.2R 80 K8	IE2-B.2R 80 K8	(IE1-)B.1R 80 K8	(IE1-)B.0R 71 K8	M8/891.	8	-	-	***	***
0.25	-	-	(IE1-)B.1R 80 G8	(IE1-)B.0R 71 G8	-	-	-	-	***	***
0.25	IE3-B.1R 80 G8	IE2-B.2R 80 G8	(IE1-)B.1R 80 G8	(IE1-)B.0R 71 G8	M8/891.	8	-	-	***	***
0.37	-	-	(IE1-)B.1R 90 S8	(IE1-)B.0R 80 K8	-	-	-	-	***	***
0.37	IE3-B.2R 90 S8	IE2-B.2R 90 S8	(IE1-)B.1R 90 S8	(IE1-)B.0R 80 K8	-	-	-	-	***	***
0.37	-	-	(IE1-)B.1R 90 S8	(IE1-)B.0R 80 K8	M16/891.	16	-	-	***	***
0.55	-	-	(IE1-)B.1R 90 L8	(IE1-)B.0R 80 G8	-	-	-	-	***	***
0.55	-	-	(IE1-)B.1R 90 L8	(IE1-)B.0R 80 G8	-	-	-	-	***	***
0.55	IE3-B.1R 90 L8	IE2-B.2R 90 L8	(IE1-)B.1R 90 L8	(IE1-)B.0R 80 G8	M16/891.	16	-	-	***	***
0.75	-	-	(IE1-)B.1R 100 L8	(IE1-)B.0R 90 L8	-	-	-	-	***	***
0.75	-	-	(IE1-)B.1R 100 L8	(IE1-)B.0R 90 L8	-	-	-	-	***	***
0.75	IE3-B.1R 100 L8	IE2-B.1R 100 L8	(IE1-)B.1R 100 L8	(IE1-)B.0R 90 L8	M32/891.	32	-	-	***	***
1.1	-	-	(IE1-)B.1R 100 LX8	(IE1-)B.0R 100 S8	-	-	-	-	***	***
1.1	-	-	(IE1-)B.1R 100 LX8	(IE1-)B.0R 100 S8	-	-	-	-	***	***
1.1	IE3-B.1R 100 LX8	IE2-B.1R 100 LX8	(IE1-)B.1R 100 LX8	(IE1-)B.0R 100 S8	M60/891.	60	-	-	***	***
1.5	-	-	(IE1-)B.1R 112 M8	(IE1-)B.0R 100 L8	-	-	-	-	***	***
1.5	-	-	(IE1-)B.1R 112 M8	(IE1-)B.0R 100 L8	-	-	-	-	***	***
1.5	IE3-B.1R 112 MZ8	IE2-B.1R 112 MV8	(IE1-)B.1R 112 M8	(IE1-)B.0R 100 L8	M60/891.	60	-	-	***	***
2.2	-	-	(IE1-)B.1R 132 S8T	(IE1-)B.0R 100 LX8	-	-	-	-	***	***
2.2	-	-	(IE1-)B.1R 132 S8T	(IE1-)B.0R 100 LX8	M60/891.	60	-	-	***	***
2.2	-	-	(IE1-)B.1R 132 S8	(IE1-)B.0R 112 M8	M32/891.100.1	64	-	-	FDB 17	60
2.2	-	IE2-B.1R 132 S8	(IE1-)B.1R 132 S8	(IE1-)B.0R 112 M8	M32/891.100.1	64	-	-	-	-
2.2	IE3-B.1R 132 S8	-	-	-	M32/891.100.1	64	KFB 5	50	FDB 17	60
3.0	-	-	(IE1-)B.1R 132 M8	(IE1-)B.0R 112 MX8	-	-	-	-	FDB 20	100
3.0	IE3-B.1R 132 M8	-	-	-	M60/891.100.1	100	KFB 10	100	FDB 20	100
3.0	IE3-B.1R 132 M8	IE2-B.1R 132 M8	(IE1-)B.1R 132 M8	(IE1-)B.0R 112 MX8	M60/891.100.1	100	-	-	-	-
4.0	-	-	(IE1-)B.1R 160 M8	-	M60/891.100.1	100	KFB 10	100	FDB 23	150
4.0	-	IE2-B.1R 160 M8	(IE1-)B.1R 160 M8	-	-	-	-	-	-	-
4.0	IE3-B.1R 160 M8	-	-	-	-	-	KFB 10	100	FDB 20	100
4.0	IE3-B.1R 160 M8	IE2-B.1R 160 M8	(IE1-)B.1R 160 M8	(IE1-)B.0R 132 S8	M60/891.100.1	100	-	-	-	-
5.5	-	-	(IE1-)B.1R 160 MX8	(IE1-)B.0R 132 M8	M100/891.100.1	180	KFB 10	100	FDB 23	150
5.5	IE3-B.1R 160 MX8	-	-	-	M100/891.100.1	180	KFB 30/17.5	175	FDB 23	150
5.5	IE3-B.1R 160 MX8	IE2-B.2R 160 MX8	(IE1-)B.1R 160 MX8	(IE1-)B.0R 132 M8	M100/891.100.1	180	-	-	-	-
7.5	-	-	(IE1-)B.1R 160 L8	(IE1-)B.0R 160 S8	-	-	KFB 30	300	FDB 26	250
7.5	IE3-B.1R 160 L8	-	-	-	-	-	KFB 30/25	250	FDB 26	250
7.5	IE3-B.1R 160 L8	IE2-B.1R 160 L8	(IE1-)B.1R 160 L8	(IE1-)B.0R 160 S8	M100/891.100.1	180	-	-	-	-
11.0	-	-	(IE1-)B.1R 180 L8	(IE1-)B.0R 160 M8	M250/891.100.1	310	KFB 30	300	FDB 26	250
11.0	IE3-B.1R 180 L8	-	-	-	-	-	KFB 30	300	FDB 26	250
11.0	IE3-B.1R 180 L8	IE2-B.2R 180 L8	(IE1-)B.1R 180 L8	(IE1-)B.0R 160 M8	M250/891.100.1	450	-	-	-	-
15.0	-	-	(IE1-)B.1R 200 L8	(IE1-)B.0R 180 S8	M250/891.100.1	450	KFB 40	400	FDB 30	400
15.0	IE3-B.1R 200 L8	-	-	-	-	-	KFB 40	400	FDB 30	400
15.0	IE3-B.1R 200 L8	IE2-B.1R 200 L8	(IE1-)B.1R 200 L8	(IE1-)B.0R 180 S8	M250/891.100.1	450	-	-	-	-
18.5	-	-	(IE1-)B.1R 225 S8	-	M250/891.100.1	450	KFB 63	630	-	400
18.5	IE3-B.1R 225 S8	-	-	-	M250/891.100.1	450	KFB 40/47	470	-	400
18.5	IE3-B.1R 225 S8	IE2-B.2R 225 S8	(IE1-)B.1R 225 S8	-	M250/891.100.1	450	-	-	-	-
18.5	-	-	-	(IE1-)B.0R 180 M8	M250/891.100.1	450	-	-	-	-
22.0	-	-	(IE1-)B.1R 225 M8	(IE1-)B.0R 200 M8	M500/891.100.1	500	KFB 63	630	FDB 30	400
22.0	IE3-B.1R 225 M8	-	-	-	M500/891.100.1	500	KFB 63	630	FDB 30	400
22.0	IE3-B.1R 225 M8	IE3-B.2R 225 M8	-	-	M500/891.100.1	500	-	-	-	-
30.0	-	-	(IE1-)B.1R 250 M8	(IE1-)B.0R 225 M8	M500/891.100.1	500	KFB 63	630	FDB 30	400
30.0	IE3-B.1R 250 M8	-	-	-	M500/891.100.1	500	KFB 63	630	FDB 30	400
30.0	IE3-B.1R 250 M8	IE2-B.1R 250 M8	(IE1-)B.1R 250 M8	(IE1-)B.0R 225 M8	M500/891.100.1	500	-	-	-	-
37.0	-	-	(IE1-)B.1R 280 S8	(IE1-)B.0R 250 S8	M500/891.100.1	500	KFB 100	1000	FDB 30	400
37.0	IE3-B.1R 280 S8	-	(IE1-)B.1R 280 S8	(IE1-)B.0R 250 S8	M500/891.100.1	500	KFB 100	1000	-	-
37.0	IE3-B.1R 280 S8	IE2-B.1R 280 S8	(IE1-)B.1R 280 S8	(IE1-)B.0R 250 S8	M500/891.100.1	500	-	-	-	-
45.0	-	-	(IE1-)B.1R 280 M8	(IE1-)B.0R 250 M8	-	-	-	-	-	-
45.0	IE3-B.1R 280 M8	-	(IE1-)B.1R 280 M8	(IE1-)B.0R 250 M8	M500/891.100.1	700	KFB 100	1000	-	-
45.0	IE3-B.1R 280 M8	IE2-B.1R 280 M8	(IE1-)B.1R 280 M8	(IE1-)B.0R 250 M8	M500/891.100.1	700	-	-	-	-

8-pole Brake motors Built-on brake with squirrel-cage rotor; Mayr, Pintsch-Bubbenzer, Precima brake

Premium Efficiency IE3/High Efficiency IE2/Standard Efficiency IE1 according to IEC/EN 60034-30-1

P _B P _B KW	For motor IE3-	For motor IE2-	For motor (IE1-)B.1R	For motor (IE1-)B.0R	Mayr M 800/891 (IP65)	Nm	Pintsch-Bubbenzer KFB/SFB	Nm	Precima FDB	Nm
55.0	-	-	(IE1-)B.1R 315 S8	(IE1-)B.0R 280 S8	-	-	KFB 160	1600	-	-
55.0	IE3-B.2R 315 S8	-	-	-	-	-	KFB 100	1000	-	-
55.0	IE3-B.2R 315 S8	IE2-B.1R 315 S8	(IE1-)B.1R 315 S8	(IE1-)B.0R 280 S8	-	-	-	-	-	-
75.0	-	IE2-B.1R 315 M8	(IE1-)B.1R 315 M8	(IE1-)B.0R 280 M8	-	-	-	-	-	-
75.0	IE3-B.1R 315 M8	-	(IE1-)B.1R 315 M8	(IE1-)B.0R 280 M8	-	-	KFB 160	1600	-	-
75.0	IE3-B.1R 315 M8	-	-	-	-	-	-	-	-	-
90.0	-	IE2-B.1R 315 MX8	(IE1-)B.1R 315 MX8	(IE1-)B.0R 315 S8	-	-	-	-	-	-
90.0	IE3-B.1R 315 MX8	-	(IE1-)B.1R 315 MX8	(IE1-)B.0R 315 S8	-	-	KFB 160	1600	-	-
90.0	IE3-B.1R 315 MX8	-	-	-	-	-	-	-	-	-
110.0	-	-	(IE1-)B.1R 315 MY8	(IE1-)B.0R 315 M8	-	-	SFB 250	2500	-	-
110.0	IE3-B.1R 315 MY8	IE2-B.1R 315 MY8	(IE1-)B.1R 315 MY8	(IE1-)B.0R 315 M8	-	-	-	-	-	-
132.0	-	-	(IE1-)B.1R 315 L8	(IE1-)B.0R 315 L8	-	-	SFB 250	2500	-	-
132.0	IE3-B.1R 315 L8	-	-	-	-	-	KFB 160	1600	-	-
132.0	IE3-B.1R 315 L8	IE2-B.1R 315 L8	(IE1-)B.1R 315 L8	(IE1-)B.0R 315 L8	-	-	-	-	-	-
160.0	-	-	(IE1-)B.1R 315 LX8	(IE1-)B.0R 315 LX8	-	-	SFB 250	2500	-	-
160.0	-	IE2-B.1R 315 LX8	(IE1-)B.1R 315 LX8	(IE1-)B.0R 315 LX8	-	-	-	-	-	-
160.0	-	-	(IE1-)B.2R 355 MY8	-	-	-	SFB 250	2500	-	-
160.0	IE3-B.1R 355 MY8	IE2-B.2R 355 MY8	(IE1-)B.2R 355 MY8	-	-	-	-	-	-	-
200.0	-	-	(IE1-)B.2R 355 M8	-	-	-	SFB 250	2500	-	-
200.0	IE3-B.1R 355 M8	-	-	-	-	-	SFB 250	2500	-	-
200.0	IE3-B.1R 355 M8	IE2-B.2R 355 M8	(IE1-)B.2R 355 M8	-	-	-	-	-	-	-
250.0	-	-	(IE1-)B.2R 355 MX8	-	-	-	SFB 250	2500	-	-
250.0	-	IE2-B.2R 355 MX8	(IE1-)B.2R 355 MX8	-	-	-	-	-	-	-
250.0	IE3-B.2R 355 MX8	-	-	-	-	-	SFB 250	2500	-	-
280.0	-	-	(IE1-)B.2R 355 LY8	-	-	-	SFB 250	2500	-	-
280.0	-	IE2-B.2R 355 LY8	(IE1-)B.2R 355 LY8	-	-	-	-	-	-	-
315.0	IE3-B.2R 400 MY8	-	-	-	-	-	***)	-	-	-
355.0	IE3-B.2R 400 M8	-	-	-	-	-	***)	-	-	-
400.0	IE3-B.2R 400 MX8	-	-	-	-	-	***)	-	-	-
450.0	IE3-B.2R 400 L8	-	-	-	-	-	***)	-	-	-

Corresponding basic version plus brake and brake mounting (see Extra price list)

Sizes 56–132 T plus rectifier (see Brake accessories)

(IE1-) can be supplied with and without marking of IE classification

***) upon request

Brake accessories

Accessories for Stromag brakes

Brake Stromag	M _H Nm	Manual release	Microswitch	Heating tape*	Rectifier
BZFM 0.25	3	X	X	-	X
BZFM 0.63	6.3	X	X	-	X
BZFM 1.60	13.5	X	X	-	X
BZFM 2.5	27	X	X	-	X
BZFM 4	37	X	X	-	X
BZFM 6.3	65	X	X	-	X
BZFM 10	100	X	X	-	X
BZFM 16	200	X	X	-	X
BZFM 25	380	X	X	-	X
*only applicable for 4BZFM					
4BZFM 16	160	-	X	X	X
4BZFM 25	250	-	X	X	X
4BZFM 40	400	-	X	X	X
4BZFM 63	630	-	X	X	X
4BZFM 100	1000	-	X	X	X
4BZFM 160	1600	-	X	X	X
4BZFM 250	2500	-	X	X	X

Accessories for Stromag brakes

Brake Stromag	M _H Nm	Manual release	Microswitch	Heating tape	Rectifier
NFF 10	100	X	X	X	X
NFF 16	160	X	X	X	X
NFF 25	250	X	X	X	X
NFF 40	400	X	X	X	X
NFF 63	630	X	X	X	X
NFF 100	1000	X	X	X	X
NFF 160	1600	X	X	***)	X
NFF 250	2500	-	X	***)	X
NFF 400	4000	-	X	***)	X

Accessories for Intorq brakes

Brake Intorq	M _H Nm	Manual release	Microswitch	Heating tape	Rectifier
BFK458-06	4	X	-	X	X
BFK458-08	8	X	-	X	X
BFK458-10	16	X	-	X	X
BFK458-12	32	X	X	X	X
BFK458-14	60	X	X	X	X
BFK458-16	80	X	X	X	X
BFK458-18	150	X	X	X	X
BFK458-20	260	X	X	X	X
BFK458-25	400	X	X	X	X

Accessories for Mayr brakes

Brake Mayr	M _H Nm	Manual release	Microswitch	Heating tape	Rectifier
3/800.412.3	3	x	***)	***)	x
4/800.412.3	6	x	***)	***)	x
6/800.412.3	26	x	***)	***)	x
7/800.412.3	50	x	***)	***)	x
M32/891.100.1	64	x	x	-	x
M60/891.100.1	100	x	x	x	x
M100/891.100.1	180	x	x	x	x
M150/891.100.1	250	x	x	x	x
M250/891.100.1	310	x	x	-	x
M500/891.100.1	500	x	x	-	x
M1000/891.100.1	1000	x	x	-	x

*) Emergency manual release only

Accessories for Pintsch-Bubbenzer brakes

Brake Pintsch-Bubbenzer	M _H Nm	Manual release	Microswitch	Heating tape	Rectifier
KFB 5	50	x	x	x	x
KFB 10	100	x	x	x	x
KFB 16	160	x	x	x	x
KFB 30	300	x	x	x	x
KFB 40	400	x	x	x	x
KFB 63	630	x	x	x	x
KFB 100	1000	x	x	x	x
KFB 160	1600	x	x	x	x
SFB 250	2500	-	x	x	x
SFB 250/330	3300	-	x	x	x

Accessories for Precima brakes

Brake FDB	M _H Nm	Manual release	Microswitch	Heating tape	Rectifier
15	40	x	***)	***)	x
17	60	x	***)	***)	x
20	100	x	***)	***)	x
23	150	x	***)	***)	x
26	250	x	***)	***)	x
30	400	x	***)	***)	x
40	1000	x	***)	***)	x

***) upon request

Brake motors with squirrel-cage rotor, three-phase Temporiti brake

Standard Efficiency IE1 according to IEC/EN 60034-30-1

Construction type IM B3, duty type S1, degree of protection IP 55, thermal class 155

P _B kW	Type	Type	Brake	M _H Nm
Synchronous speed 3000 rpm – 2-pole version				
0.18	(IE1-)B21R 63 K2	(IE1-)B20R 56 K2	AC 1	4
0.25	(IE1-)B21R 63 G2	(IE1-)B20R 56 G2	AC 1	4
0.37	(IE1-)B21R 71 K2	(IE1-)B20R 63 K2	AC 1	4
0.55	(IE1-)B21R 71 G2	(IE1-)B20R 63 G2	AC 1	4
0.75	(IE1-)B21R 80 K2	(IE1-)B20R 71 K2	AC 1	4
1.1	(IE1-)B21R 80 G2	(IE1-)B20R 71 G2	AC 1	4
1.5	(IE1-)B21R 90 S2	(IE1-)B20R 80 K2	AC 2	8
2.2	(IE1-)B21R 90 L2	(IE1-)B20R 80 G2	AC 2	8
3.0	(IE1-)B21R 100 L2	(IE1-)B20R 90 L2	AC 4	16
4.0	(IE1-)B21R 112 M2	(IE1-)B20R 100 S2	AC 5	35
4.0	(IE1-)B21R 112 M2	(IE1-)B20R 100 S2	AC 6	60
5.5	(IE1-)B21R 132 S2T	(IE1-)B20R 100 L2	AC 5	35
5.5	(IE1-)B21R 132 S2T	(IE1-)B20R 100 L2	AC 6	60
7.5	(IE1-)B21R 132 SX2T	(IE1-)B20R 100 LV2*)	AC 5	35
7.5	(IE1-)B21R 132 SX2T	(IE1-)B20R 100 LV2*)	AC 6	60
Synchronous speed 1500 rpm – 4-pole version				
0.12	(IE1-)B21R 63 K4	(IE1-)B20R 56 K4	AC 1	4
0.18	(IE1-)B21R 63 G4	(IE1-)B20R 56 G4	AC 1	4
0.25	(IE1-)B21R 71 K4	(IE1-)B20R 63 K4	AC 1	4
0.37	(IE1-)B21R 71 G4	(IE1-)B20R 63 G4	AC 1	4
0.55	(IE1-)B21R 80 K4	(IE1-)B20R 71 K4	AC 1	4
0.75	(IE1-)B21R 80 G4	(IE1-)B20R 71 G4	AC 1	4
1.1	(IE1-)B21R 90 S4	(IE1-)B20R 80 K4	AC 2	8
1.5	(IE1-)B21R 90 L4	(IE1-)B20R 80 G4	AC 2	8
2.2	(IE1-)B21R 100 L4	(IE1-)B20R 90 L4	AC 4	16
3.0	(IE1-)B21R 100 LX4	(IE1-)B20R 100 S4	AC 5	35
3.0	(IE1-)B21R 100 LX4	(IE1-)B20R 100 S4	AC 6	60
4.0	(IE1-)B21R 112 M4	(IE1-)B20R 100 L4	AC 5	35
4.0	(IE1-)B21R 112 M4	(IE1-)B20R 100 L4	AC 6	60
5.5	(IE1-)B21R 132 S4T	(IE1-)B20R 100 LX4*)	AC 5	35
5.5	(IE1-)B21R 132 S4T	(IE1-)B20R 100 LX4*)	AC 6	60

Corresponding basic version plus brake

*) No manual release possible

(IE1-) can be supplied with and without marking of IE classification

Brake motors with squirrel-cage rotor, three-phase Temporiti brake

Standard Efficiency IE1 according to IEC/EN 60034-30-1

Construction type IM B3, duty type S1, degree of protection IP 55, thermal class 155

P _B kW	Type	Type	Brake	M _H Nm
Synchronous speed 1000 rpm – 6-pole version				
0.09	(IE1-)B21R 63 K6	(IE1-)B20R 56 K6	AC 1	4
0.12	(IE1-)B21R 63 G6	(IE1-)B20R 56 G6	AC 1	4
0.18	(IE1-)B21R 71 K6	(IE1-)B20R 63 K6	AC 1	4
0.25	(IE1-)B21R 71 G6	(IE1-)B20R 63 G6	AC 1	4
0.37	(IE1-)B21R 80 K6	(IE1-)B20R 71 K6	AC 1	4
0.55	(IE1-)B21R 80 G6	(IE1-)B20R 71 G6	AC 1	4
0.75	(IE1-)B21R 90 S6	(IE1-)B20R 80 K6	AC 2	8
1.1	(IE1-)B21R 90 L6	(IE1-)B20R 80 G6	AC 2	8
1.5	(IE1-)B21R 100 L6	(IE1-)B20R 90 L6	AC 4	16
2.2	(IE1-)B21R 112 M6	(IE1-)B20R 100 L6	AC 5	35
2.2	(IE1-)B21R 112 M6	(IE1-)B20R 100 L6	AC 6	60
3.0	(IE1-)B21R 132 S6T	(IE1-)B20R 100 LX6	AC 5	35
3.0	(IE1-)B21R 132 S6T	(IE1-)B20R 100 LX6	AC 6	60
Synchronous speed 750 rpm – 8-pole version				
0.09	(IE1-)B21R 71 K8	(IE1-)B20R 63 K8	AC 1	4
0.12	(IE1-)B21R 71 G8	(IE1-)B20R 63 G8	AC 1	4
0.18	(IE1-)B21R 80 K8	(IE1-)B20R 71 K8	AC 1	4
0.25	(IE1-)B21R 80 G8	(IE1-)B20R 71 G8	AC 1	4
0.37	(IE1-)B21R 90 S8	(IE1-)B20R 80 K8	AC 2	8
0.55	(IE1-)B21R 90 L8	(IE1-)B20R 80 G8	AC 2	8
0.75	(IE1-)B21R 100 L8	(IE1-)B20R 90 L8	AC 4	16
1.1	(IE1-)B21R 100 LX8	(IE1-)B20R 100 S8	AC 5	35
1.1	(IE1-)B21R 100 LX8	(IE1-)B20R 100 S8	AC 6	60
1.5	(IE1-)B21R 112 M8	(IE1-)B20R 100 L8	AC 5	35
1.5	(IE1-)B21R 112 M8	(IE1-)B20R 100 L8	AC 6	60
2.2	(IE1-)B21R 132 S8T	(IE1-)B20R 100 LX8	AC 5	35
2.2	(IE1-)B21R 132 S8T	(IE1-)B20R 100 LX8	AC 6	60

Corresponding basic version plus brake

¹⁾ No manual release possible

(IE1-) can be supplied with and without marking of IE classification

**Explosion-protected brake motors with squirrel-cage rotor, Mayr brake
CE 0637 Ex tD A 21 IP 65 T 125 °C**

Standard Efficiency IE1 according to IEC/EN 60034-30

Brake motors for use in Zone 21 according to EN 61241-1

Thermal class 155, degree of protection IP 65, max. surface temperature 125 °C

Construction type IM B3, duty type S4 40 %, 1 set PTC thermistors (TPM140)

Version for rated voltage range A according to IEC/EN 60034-1, 50 Hz

P _B kW	Type	Type	Brake	M _H Nm
Synchronous speed 3000 rpm – 2-pole version				
0.18	(IE1-)BPER 63 K2	(IE1-)BPR 56 K2	M2	2
0.25	(IE1-)BPER 63 G2	(IE1-)BPR 56 G2	M2	2
0.37	(IE1-)BPER 71 K2	(IE1-)BPR 63 K2	M2	2
0.37	(IE1-)BPER 71 K2	(IE1-)BPR 63 K2	M4	4
0.55	(IE1-)BPER 71 G2	(IE1-)BPR 63 G2	M2	2
0.55	(IE1-)BPER 71 G2	(IE1-)BPR 63 G2	M4	4
0.75	(IE1-)BPER 80 K2	(IE1-)BPR 71 K2	M4	4
0.75	(IE1-)BPER 80 K2	(IE1-)BPR 71 K2	M8	8
1.1	(IE1-)BPER 80 G2	(IE1-)BPR 71 G2	M4	4
1.1	(IE1-)BPER 80 G2	(IE1-)BPR 71 G2	M8	8
1.5	(IE1-)BPER 90 S2	(IE1-)BPR 80 K2	M8	8
1.5	(IE1-)BPER 90 S2	(IE1-)BPR 80 K2	M16	16
2.2	(IE1-)BPER 90 L2	(IE1-)BPR 80 G2	M8	8
2.2	(IE1-)BPER 90 L2	(IE1-)BPR 80 G2	M16	16
3.0	(IE1-)BPER 100 L2	(IE1-)BPR 90 L2	M16	16
3.0	(IE1-)BPER 100 L2	(IE1-)BPR 90 L2	M32	32
4.0	(IE1-)BPER 112 M2	(IE1-)BPR 100 S2	M32	32
4.0	(IE1-)BPER 112 M2	(IE1-)BPR 100 S2	M60	60
5.5	(IE1-)BPER 132 S2T	-	M32	32
5.5	(IE1-)BPER 132 S2T	-	M60	60
7.5	(IE1-)BPER 132 SX2T	-	M32	32
7.5	(IE1-)BPER 132 SX2T	-	M60	60
Synchronous speed 1500 rpm – 4-pole version				
0.12	(IE1-)BPER 63 K4	(IE1-)BPR 56 K4	M2	2
0.18	(IE1-)BPER 63 G4	(IE1-)BPR 56 G4	M2	2
0.25	(IE1-)BPER 71 K4	(IE1-)BPR 63 K4	M2	2
0.25	(IE1-)BPER 71 K4	(IE1-)BPR 63 K4	M4	4
0.37	(IE1-)BPER 71 G4	(IE1-)BPR 63 G4	M2	2
0.37	(IE1-)BPER 71 G4	(IE1-)BPR 63 G4	M4	4
0.55	(IE1-)BPER 80 K4	(IE1-)BPR 71 K4	M4	4
0.55	(IE1-)BPER 80 K4	(IE1-)BPR 71 K4	M8	8
0.75	(IE1-)BPER 80 G4	(IE1-)BPR 71 G4	M4	4
0.75	(IE1-)BPER 80 G4	(IE1-)BPR 71 G4	M8	8
1.1	(IE1-)BPER 90 S4	(IE1-)BPR 80 K4	M8	8
1.1	(IE1-)BPER 90 S4	(IE1-)BPR 80 K4	M16	16
1.5	(IE1-)BPER 90 L4	(IE1-)BPR 80 G4	M8	8
1.5	(IE1-)BPER 90 L4	(IE1-)BPR 80 G4	M16	16
2.2	(IE1-)BPER 100 L4	(IE1-)BPR 90 L4	M16	16
2.2	(IE1-)BPER 100 L4	(IE1-)BPR 90 L4	M32	32
3.0	(IE1-)BPER 100 LX4	(IE1-)BPR 100 S4	M32	32
3.0	(IE1-)BPER 100 LX4	(IE1-)BPR 100 S4	M60	60
4.0	(IE1-)BPER 112 M4	(IE1-)BPR 100 L4	M32	32
4.0	(IE1-)BPER 112 M4	(IE1-)BPR 100 L4	M60	60
5.5	(IE1-)BPER 132 S4T	-	M32	32
5.5	(IE1-)BPER 132 S4T	-	M60	60

Corresponding basic version plus brake

(IE1-) can be supplied with and without marking of IE classification

Explosion-protected brake motors with squirrel-cage rotor, Mayr brake CE 0637 Ex tD A 21 IP 65 T 125 °C

Standard Efficiency IE1 according to IEC/EN 60034-30

Brake motors for use in Zone 21 according to EN 61241-1

thermal class 155, degree of protection IP 65, max. surface temperature 125 °C

Construction type IM B3, duty type S4 40 %, 1 set PTC thermistors (TPM140)

Version for rated voltage range A according to IEC/EN 60034-1, 50 Hz

P _B kW	Type	Type	Brake	M _H Nm
Synchronous speed 1000 rpm – 6-pole version				
0.09	(IE1-)BPER 63 K6	(IE1-)BPR 56 K6	M2	2
0.12	(IE1-)BPER 63 G6	(IE1-)BPR 56 G6	M2	2
0.18	(IE1-)BPER 71 K6	(IE1-)BPR 63 K6	M2	2
0.18	(IE1-)BPER 71 K6	(IE1-)BPR 63 K6	M4	4
0.25	(IE1-)BPER 71 G6	(IE1-)BPR 63 G6	M2	2
0.25	(IE1-)BPER 71 G6	(IE1-)BPR 63 G6	M4	4
0.37	(IE1-)BPER 80 K6	(IE1-)BPR 71 K6	M4	4
0.37	(IE1-)BPER 80 K6	(IE1-)BPR 71 K6	M8	8
0.55	(IE1-)BPER 80 G6	(IE1-)BPR 71 G6	M4	4
0.55	(IE1-)BPER 80 G6	(IE1-)BPR 71 G6	M8	8
0.75	(IE1-)BPER 90 S6	(IE1-)BPR 80 K6	M8	8
0.75	(IE1-)BPER 90 S6	(IE1-)BPR 80 K6	M16	16
1.1	(IE1-)BPER 90 L6	(IE1-)BPR 80 G6	M8	8
1.1	(IE1-)BPER 90 L6	(IE1-)BPR 80 G6	M16	16
1.5	(IE1-)BPER 100 L6	(IE1-)BPR 90 L6	M16	16
1.5	(IE1-)BPER 100 L6	(IE1-)BPR 90 L6	M32	32
2.2	(IE1-)BPER 112 M6	(IE1-)BPR 100 L6	M32	32
2.2	(IE1-)BPER 112 M6	(IE1-)BPR 100 L6	M60	60
3.0	(IE1-)BPER 132 S6T	-	M32	32
3.0	(IE1-)BPER 132 S6T	-	M60	60
Synchronous speed 750 rpm – 8-pole version				
0.09	(IE1-)BPER 71 K8	BPR 63 K8	M2	2
0.09	(IE1-)BPER 71 K8	BPR 63 K8	M4	4
0.12	(IE1-)BPER 71 G8	BPR 63 G8	M2	2
0.12	(IE1-)BPER 71 G8	BPR 63 G8	M4	4
0.18	(IE1-)BPER 80 K8	BPR 71 K8	M4	4
0.18	(IE1-)BPER 80 K8	BPR 71 K8	M8	8
0.25	(IE1-)BPER 80 G8	BPR 71 G8	M4	4
0.25	(IE1-)BPER 80 G8	BPR 71 G8	M8	8
0.37	(IE1-)BPER 90 S8	BPR 80 K8	M8	8
0.37	(IE1-)BPER 90 S8	BPR 80 K8	M16	16
0.55	(IE1-)BPER 90 L8	BPR 80 G8	M8	8
0.55	(IE1-)BPER 90 L8	BPR 80 G8	M16	16
0.75	(IE1-)BPER 100 L8	BPR 90 L8	M16	16
0.75	(IE1-)BPER 100 L8	BPR 90 L8	M32	32
1.1	(IE1-)BPER 100 LX8	BPR 100 S8	M32	32
1.1	(IE1-)BPER 100 LX8	BPR 100 S8	M60	60
1.5	(IE1-)BPER 112 M8	BPR 100 L8	M32	32
1.5	(IE1-)BPER 112 M8	BPR 100 L8	M60	60
2.2	(IE1-)BPER 132 S8T	BPR 100 LX8	M32	32
2.2	(IE1-)BPER 132 S8T	BPR 100 LX8	M60	60

Corresponding basic version plus brake

(IE1-) can be supplied with and without marking of IE classification

Brake motors with built-on compact brake Intorq BFK 457

Standard Efficiency IE1 according to IEC/EN 60034-30
 Construction type IM B3, degree of protection IP 54, thermal class 155

P_B kW	Type	Type	M_H Nm
Synchronous speed 3000 rpm – 2-pole version			
0.18	B21R 63 K2 BLEN	B20R 56 K2 BLEN	2
0.25	B21R 63 G2 BLEN	B20R 56 G2 BLEN	2
0.37	B21R 71 K2 BLEN	B20R 63 K2 BLEN	2
0.55	B21R 71 G2 BLEN	B20R 63 G2 BLEN	2
0.75	B21R 80 K2 BLEN	B20R 71 K2 BLEN	4
1.1	B21R 80 G2 BLEN	B20R 71 G2 BLEN	4
1.5	B21R 90 S2 BLEN	B20R 80 K2 BLEN	8
2.2	B21R 90 L2 BLEN	B20R 80 G2 BLEN	8
3.0	B21R 100 L2 BLEN	B20R 90 L2 BLEN	16
4.0	B21R 112 M2 BLEN	B20R 100 S2 BLEN	16
5.5	B21R 112 MX2 BLEN	B20R 100 L2 BLEN	16
Synchronous speed 1500 rpm – 4-pole version			
0.12	B21R 63 K4 BLEN	B20R 56 K4 BLEN	2
0.18	B21R 63 G4 BLEN	B20R 56 G4 BLEN	2
0.25	B21R 71 K4 BLEN	B20R 63 K4 BLEN	2
0.37	B21R 71 G4 BLEN	B20R 63 G4 BLEN	2
0.55	B21R 80 K4 BLEN	B20R 71 K4 BLEN	4
0.75	B21R 80 G4 BLEN	B20R 71 G4 BLEN	4
1.1	B21R 90 S4 BLEN	B20R 80 K4 BLEN	8
1.5	B21R 90 L4 BLEN	B20R 80 G4 BLEN	8
2.2	B21R 100 L4 BLEN	B20R 90 L4 BLEN	16
3.0	B21R 100 LX4 BLEN	B20R 100 S4 BLEN	16
4.0	B21R 112 M4 BLEN	B20R 100 L4 BLEN	16
Synchronous speed 1000 rpm – 6-pole version			
0.12	B21R 63 G6 BLEN	B20R 56 G6 BLEN	2
0.18	B21R 71 K6 BLEN	B20R 63 K6 BLEN	2
0.25	B21R 71 G6 BLEN	B20R 63 G6 BLEN	2
0.37	B21R 80 K6 BLEN	B20R 71 K6 BLEN	4
0.55	B21R 80 G6 BLEN	B20R 71 G6 BLEN	4
0.75	B21R 90 S6 BLEN	B20R 80 K6 BLEN	8
1.1	B21R 90 L6 BLEN	B20R 80 G6 BLEN	8
1.5	B21R 100 L6 BLEN	B20R 90 L6 BLEN	16
2.2	B21R 112 M6 BLEN	B20R 100 L6 BLEN	16
Synchronous speed 750 rpm – 8-pole version			
0.12	B21R 71 G8 BLEN	B20R 63 G8 BLEN	2
0.18	B21R 80 K8 BLEN	B20R 71 K8 BLEN	4
0.25	B21R 80 G8 BLEN	B20R 71 G8 BLEN	4
0.37	B21R 90 S8 BLEN	B20R 80 K8 BLEN	8
0.55	B21R 90 L8 BLEN	B20R 80 G8 BLEN	8
0.75	B21R 100 L8 BLEN	B20R 90 L8 BLEN	16
1.1	B21R 100 LX8 BLEN	B20R 100 S8 BLEN	16
1.5	B21R 112 M8 BLEN	B20R 100 L8 BLEN	16

(IE1-) can be supplied with and without marking of IE classification

Explosion-protected brake motors with squirrel-cage rotor, Mayr brake CE 0637 Ex II 3D Ex tc IIIB T 125 °C Dc

Standard Efficiency IE1 according to IEC/EN 60034-30-1

Brake motors for use in Zone 22 according to EN 60079-31

thermal class 155, degree of protection IP 55, max. surface temperature 125 °C

Construction type IM B3, duty type S1, 1 set PTC thermistors (TPM130)

Version for rated voltage range A according to IEC/EN 60034-1, 50 Hz

P _B kW	Type	Type	Brake	M _H Nm
Synchronous speed 3000 rpm – 2-pole version				
5.5	(IE1-)B21R 132 S2 ¹⁾	(IE1-)B20R 112 MY2 ¹⁾	M32/891.010.1	40
7.5	(IE1-)B21R 132 SX2 ¹⁾	(IE1-)B20R 112 M2 ¹⁾	M32/891.010.1	64
11.0	(IE1-)B21R 160 M2 ¹⁾	(IE1-)B20R 132 M2 ¹⁾	M32/891.010.1	64
15.0	(IE1-)B21R 160 MX2 ¹⁾	(IE1-)B20R 160 S2 ¹⁾	M60/891.010.1	100
18.5	(IE1-)B21R 160 L2 ¹⁾	(IE1-)B20R 160 M2 ¹⁾	M100/891.010.1	180
22.0	(IE1-)B21R 180 M2 ¹⁾	(IE1-)B20R 180 S2 ¹⁾	M150/891.010.1	150
30.0	(IE1-)B21R 200 L2 ¹⁾	(IE1-)B20R 180 M2 ¹⁾	M150/891.010.1	250
37.0	(IE1-)B21R 200 LX2 ¹⁾	(IE1-)B20R 200 M2 ¹⁾	M250/891.010.1	310
45.0	(IE1-)B21R 225 M2 ¹⁾	(IE1-)B20R 200 L2 ¹⁾	M250/891.010.1	310
55.0	(IE1-)B21R 250 M2 ¹⁾	(IE1-)B20R 225 M2 ¹⁾	M500/891.010.1	500
75.0	(IE1-)B21R 280 S2 ¹⁾	(IE1-)B20R 250 S2 ¹⁾	-	-
90.0	(IE1-)B21R 280 M2 ¹⁾	(IE1-)B20R 250 M2 ¹⁾	-	-
Synchronous speed 1500 rpm – 4-pole version				
5.5	(IE1-)B21R 132 S4	(IE1-)B20R 112 M4	M32/891.010.1	64
7.5	(IE1-)B21R 132 M4	(IE1-)B20R 132 S4	M60/891.010.1	100
11.0	(IE1-)B21R 160 M4	(IE1-)B20R 132 M4	M100/891.010.1	180
15.0	(IE1-)B21R 160 L4	(IE1-)B20R 160 S4	M100/891.010.1	180
18.5	(IE1-)B21R 180 M4	(IE1-)B20R 160 M4	M150/891.010.1	250
22.0	(IE1-)B21R 180 L4	(IE1-)B20R 180 S4	M250/891.010.1	310
30.0	(IE1-)B21R 200 L4	(IE1-)B20R 180 M4	M250/891.010.1	450
37.0	(IE1-)B21R 225 S4	(IE1-)B20R 200 M4	M250/891.010.1	450
45.0	(IE1-)B21R 225 M4	(IE1-)B20R 200 L4	M500/891.010.1	500
55.0	(IE1-)B21R 250 M4	(IE1-)B20R 225 M4	M500/891.010.1	500
75.0	(IE1-)B21R 280 S4	(IE1-)B20R 250 S4	M500/891.010.1	500
90.0	(IE1-)B21R 280 M4	(IE1-)B20R 250 M4	M500/891.010.1	750
Synchronous speed 1000 rpm – 6-pole version				
3.0	(IE1-)B21R 132 S6	(IE1-)B20R 112 M6	M32/891.010.1	64
4.0	(IE1-)B21R 132 M6	(IE1-)B20R 112 MX6	M60/891.010.1	100
5.5	(IE1-)B21R 132 MX6	(IE1-)B20R 132 S6	M60/891.010.1	100
7.5	(IE1-)B21R 160 M6	(IE1-)B20R 132 M6	M100/891.010.1	180
11.0	(IE1-)B21R 160 L6	(IE1-)B20R 160 S6	M150/891.010.1	250
15.0	(IE1-)B21R 180 L6	(IE1-)B20R 160 M6	M250/891.010.1	310
18.5	(IE1-)B21R 200 L6	(IE1-)B20R 180 S6	M250/891.010.1	450
22.0	(IE1-)B21R 200 LX6	(IE1-)B20R 180 M6	M250/891.010.1	450
30.0	(IE1-)B21R 225 M6	(IE1-)B20R 200 M6	M500/891.010.1	500
37.0	(IE1-)B21R 250 M6	(IE1-)B20R 225 M6	M500/891.010.1	500
45.0	(IE1-)B21R 280 S6	(IE1-)B20R 250 S6	M500/891.010.1	500
55.0	(IE1-)B21R 280 M6	(IE1-)B20R 250 M6	M500/891.010.1	560
Synchronous speed 750 rpm – 8-pole version				
2.2	(IE1-)B21R 132 S8	(IE1-)B20R 112 M8	M32/891.010.1	64
3.0	(IE1-)B21R 132 M8	(IE1-)B20R 112 MX8	M60/891.010.1	100
4.0	(IE1-)B21R 160 M8	(IE1-)B20R 132 S8	M60/891.010.1	100
5.5	(IE1-)B21R 160 MX8	(IE1-)B20R 132 M8	M100/891.010.1	180
7.5	(IE1-)B21R 160 L8	(IE1-)B20R 160 S8	M100/891.010.1	180
11.0	(IE1-)B21R 180 L8	(IE1-)B20R 160 M8	M250/891.010.1	310
15.0	(IE1-)B21R 200 L8	(IE1-)B20R 180 S8	M250/891.010.1	450
18.5	-	(IE1-)B20R 180 M8	M250/891.010.1	-
18.5	(IE1-)B21R 225 S8	-	M250/891.010.1	450
22.0	(IE1-)B21R 225 M8	(IE1-)B20R 200 M8	M500/891.010.1	500
30.0	(IE1-)B21R 250 M8	(IE1-)B20R 225 M8	M500/891.010.1	500
37.0	(IE1-)B21R 280 S8	(IE1-)B20R 250 S8	M500/891.010.1	500
45.0	(IE1-)B21R 280 M8	(IE1-)B20R 250 M8	M500/891.010.1	700

Corresponding basic version plus brake

¹⁾ Requires consultation regarding application

(IE1-) can be supplied with and without marking of IE classification

Fan assignments

Built-on fans, type of cooling IC 416, Fan unit FBW (Wistro) for squirrel-cage motors, 2-pole

Premium Efficiency IE3/High Efficiency IE2/Standard Efficiency IE1 according to IEC/EN 60034-30-1

PB kW	Series				Fan unit
	For motor IE3-	For motor IE2-	For motor (IE1-)K.1R	For motor (IE1-)K.0R	
0.12	IE3-W.1F 56 G2	IE2-W.2F 56 G2	***)	***)	FBW 63
0.18	IE3-W.2F 63 K2	IE2-W.2F 63 K2	***)	***)	FBW 63
0.25	-	IE2-W.2F 63 G2	***)	***)	FBW 63
0.25	IE3-W.1F 63 G2	-	***)	***)	FBW 71
0.37	IE3-W.2F 71 K2	IE2-W.2F 71 K2	***)	***)	FBW 71
0.55	-	IE2-W.1F 71 G2	***)	***)	FBW 71
0.55	IE3-W.1F 71 GY2	-	***)	***)	FBW 80
0.75	-	-	(IE1-)K.1F 80 K2	(IE1-)K.0F 71 K2	FBW 80
0.75	IE3-W.1F 80 K2	IE2-W.1F 80 K2	-	-	FBW 90
1.1	-	-	(IE1-)K.1F 80 G2	(IE1-)K.0F 71 G2	FBW 80
1.1	IE3-W.1F 80 G2	IE2-W.1F 80 G2	-	-	FBW 90
1.5	-	-	(IE1-)K.1F 90 S2	(IE1-)K.0F 80 K2	FBW 90
1.5	IE3-W.1F 90 S2	IE2-W.1F 90 S2	-	-	FBW 100
2.2	-	-	(IE1-)K.1F 90 L2	(IE1-)K.0F 80 G2	FBW 90
2.2	IE3-W.1F 90 L2	IE2-W.1F 90 L2	-	-	FBW 100
3.0	-	-	(IE1-)K.1F 100 L2	(IE1-)K.0F 90 L2	FBW 100
3.0	IE3-W.1F 100 L2	IE2-W.1F 100 L2	-	-	FBW 112
4.0	-	-	(IE1-)K.1F 112 M2	(IE1-)K.0F 100 S2	FBW 100
4.0	IE3-W.1F 112 M2	-	-	-	FBW 112
4.0	-	IE2-W.1F 112 MX2	(IE1-)K.1F 112 MX2	(IE1-)K.0F 100 L2	FBW 112
5.5	IE3-W.1F 132 S2	IE2-W.1F 132 S2T	(IE1-)K.1F 132 S2T	-	FBW 112 IL
7.5	IE3-W.1F 132 SX2	-	(IE1-)K.1F 132 SX2T	-	FBW 112 IL
11.0	-	-	(IE1-)K.1F 160 M2	(IE1-)K.0F 132 M2	FBW 132 IL
11.0	IE3-W.1F 160 M2	IE2-W.1F 160 M2	-	-	FBW 160 IL
15.0	IE3-W.1F 160 MX2	IE2-W.1F 160 MX2	(IE1-)K.1F 160 MX2	(IE1-)K.0F 160 S2	FBW 160 IL
18.5	IE3-W.1F 160 L2	IE2-W.1F 160 L2	(IE1-)K.1F 160 L2	(IE1-)K.0F 160 M2	FBW 160 IL
22.0	IE3-W.1F 180 M2C	IE2-W.1F 180 M2	(IE1-)K.1F 180 M2	(IE1-)K.0F 180 S2	FBW 180 IL
30.0	-	IE2-W.1F 200 L2	(IE1-)K.1F 200 L2	(IE1-)K.0F 180 M2	FBW 180 IL
30.0	IE3-W.1F 200 L2	-	-	-	FBW 200 IL
37.0	IE3-W.1F 200 LX2C	-	(IE1-)K.1F 200 LX2	(IE1-)K.0F 200 M2	FBW 200 IL
37.0	-	IE2-W.1F 200 LX2	-	-	FBW 180 IL
45.0	-	IE2-W.1F 225 M2	(IE1-)K.1F 225 M2	(IE1-)K.0F 200 L2	FBW 200 IL
45.0	IE3-W.1F 225 M2	-	-	-	FBW 225 IL
55.0	-	IE2-W.1F 250 M2	(IE1-)K.1F 250 M2	(IE1-)K.0F 225 M2	FBW 225 IL
55.0	IE3-W.1F 250 M2	-	-	-	FBW 250 IL
75.0	IE3-W.1F 280 S2	IE2-W.1F 280 S2	(IE1-)K.1F 280 S2	(IE1-)K.0F 250 S2	FBW 250 IL
90.0	IE3-W.1F 280 M2	IE2-W.1F 280 M2	(IE1-)K.1F 280 M2	(IE1-)K.0F 250 M2	FBW 250 IL
110.0	IE3-W.1F 315 S2	IE2-W.1F 315 S2	(IE1-)K.1F 315 S2	(IE1-)K.0F 280 S2	FBW 280 IL
132.0	IE3-W.1F 315 M2	IE2-W.1F 315 M2	(IE1-)K.1F 315 M2	(IE1-)K.0F 280 M2	FBW 280 IL
160.0	IE3-W.1F 315 MX2	IE2-W.1F 315 MX2	(IE1-)K.1F 315 MX2	(IE1-)K.0F 315 S2	FBW 280 IL
200.0	IE3-W.1F 315 MY2	IE2-W.1F 315 MY2	(IE1-)K.1F 315 MY2	(IE1-)K.0F 315 M2	FBW 315 MY IL
250.0	IE3-W.1F 315 L2	IE2-W.1F 315 L2	(IE1-)K.1F 315 L2	(IE1-)K.0F 315 L2	FBW 315 MY IL
315.0	IE3-W.1F 315 LX2	IE2-W.1F 315 LX2	(IE1-)K.1F 315 LX2	(IE1-)K.0F 315 LX2	FBW 315 LX IL
315.0	-	IE2-W.2F 355 MY2	(IE1-)K.2F 355 MY2	-	FBW 355 IL
355.0	IE3-W.1F 355 M2	IE2-W.2F 355 M2	(IE1-)K.2F 355 M2	-	FBW 355 IL
400.0	IE3-W.2F 355 MX2	IE2-W.2F 355 MX2	(IE1-)K.2F 355 MX2	-	FBW 355 IL
450.0	-	IE2-W.2F 355 LY2	(IE1-)K.2F 355 LY2	-	FBW 355 IL
500.0	IE3-W.2F 355 L2	IE2-W.2F 355 L2	(IE1-)K.2F 355 L2	-	FBW 355 IL

Corresponding basic version plus fan

Motors with forced ventilation must always be provided with thermal motor protection.

Observe catalogue data regarding outputs in converter-fed operation.

In accordance with Regulation (EC) No. 640/2009, motors in 2-, 4- and 6-pole versions for outputs from 0.75 to 355 kW may only be brought onto the market if they do not fall within the scope of applicability of the regulation on account of the operating conditions specified by the customer.

(IE1-) can be supplied with and without marking of IE classification

***) upon request

Built-on fans, type of cooling IC 416, Fan unit FBW (Wistro) for squirrel-cage motors, 4-pole

Premium Efficiency IE3/High Efficiency IE2/Standard Efficiency IE1 according to IEC/EN 60034-30-1

PB kW	Series				Fan unit
	For motor IE3-	For motor IE2-	For motor (IE1-)K.1R	For motor (IE1-)K.0R	
0.12	IE3-W.2F 63 K4	IE2-W.2F 63 K4	***)	***)	FBW 63
0.18	IE3-W.1F 63 G4	IE2-W.1F 63 GY4	***)	***)	FBW 71
0.25	IE3-W.2F 71 K4	IE2-W.1F 71 K4	(IE1-)K.1F 71 K4	(IE1-)K.0F 63 K4	FBW 71
0.37	-	-	(IE1-)K.1F 71 G4	(IE1-)K.0F 63 G4	FBW 71
0.37	IE3-W.1F 71 GY4	IE2-W.1F 71 GY4	-	-	FBW 80
0.55	-	IE2-W.1F 80 K4	(IE1-)K.1F 80 K4	(IE1-)K.0F 71 K4	FBW 80
0.75	-	-	(IE1-)K.1F 80 G4	(IE1-)K.0F 71 G4	FBW 80
0.75	IE3-W.1F 80 GX4	IE2-W.1F 80 G4	-	-	FBW 90
1.1	-	-	(IE1-)K.1F 90 S4	(IE1-)K.0F 80 K4	FBW 90
1.1	IE3-W.1F 90 S4	IE2-W.1F 90 S4	-	-	FBW 100
1.5	-	-	(IE1-)K.1F 90 L4	(IE1-)K.0F 80 G4	FBW 90
1.5	IE3-W.1F 90 LX4	IE2-W.1F 90 L4	-	-	FBW 100
2.2	-	-	(IE1-)K.1F 100 L4	(IE1-)K.0F 90 L4	FBW 100
2.2	IE3-W.1F 100 L4	IE2-W.1F 100 L4	-	-	FBW 112
3.0	IE3-W.1F 100 LZ4	IE2-W.1F 100 LX4	(IE1-)K.1F 100 LX4	(IE1-)K.0F 100 S4	FBW 112
4.0	-	IE2-W.1F 112 MZ4	(IE1-)K.1F 112 M4	(IE1-)K.0F 100 L4	FBW 112
4.0	IE3-W.1F 112 M4	IE2-W.1F 112 M4	-	-	FBW 112
5.5	-	-	(IE1-)K.1F 132 S4	(IE1-)K.0F 112 M4	FBW 112 IL
5.5	IE3-W.1F 132 S4	IE2-W.2F 132 S4	-	-	FBW 132 IL
7.5	IE3-W.1F 132 M4	IE2-W.1F 132 M4	(IE1-)K.1F 132 M4	(IE1-)K.0F 132 S4	FBW 132 IL
11.0	-	-	(IE1-)K.1F 160 M4	(IE1-)K.0F 132 M4	FBW 132 IL
11.0	IE3-W.1F 160 M4	IE2-W.2F 160 M4	-	-	FBW 160 IL
15.0	IE3-W.1F 160 L4C	IE2-W.2F 160 L4	(IE1-)K.1F 160 L4	(IE1-)K.0F 160 S4	FBW 160 IL
18.5	-	-	(IE1-)K.1F 180 M4	(IE1-)K.0F 160 M4	FBW 160 IL
18.5	IE3-W.1F 180 M4	IE2-W.1F 180 M4	-	-	FBW 180 IL
22.0	IE3-W.1F 180 L4	IE2-W.1F 180 L4	(IE1-)K.1F 180 L4	(IE1-)K.0F 180 S4	FBW 180 IL
30.0	-	-	(IE1-)K.1F 200 L4	(IE1-)K.0F 180 M4	FBW 180 IL
30.0	IE3-W.1F 200 L4C	IE2-W.1F 200 L4	-	-	FBW 200 IL
37.0	IE3-W.1F 225 S4C	IE2-W.1F 225 S4	(IE1-)K.1F 225 S4	(IE1-)K.0F 200 M4	FBW 200 IL
45.0	-	-	(IE1-)K.1F 225 M4	(IE1-)K.0F 200 L4	FBW 200 IL
45.0	IE3-W.1F 225 M4	IE2-W.2F 225 M4	-	-	FBW 225 IL
55.0	-	IE2-W.2F 250 M4	(IE1-)K.1F 250 M4	(IE1-)K.0F 225 M4	FBW 225 IL
55.0	IE3-W.1F 250 M4	-	-	-	FBW 250 IL
75.0	IE3-W.1F 280 S4	IE2-W.1F 280 S4	(IE1-)K.1F 280 S4	(IE1-)K.0F 250 S4	FBW 250 IL
90.0	-	IE2-W.1F 280 M4	(IE1-)K.1F 280 M4	(IE1-)K.0F 250 M4	FBW 250 IL
90.0	IE3-W.1F 280 M4	-	-	-	FBW 280 IL
110.0	IE3-W.1F 315 S4	IE2-W.1F 315 S4	(IE1-)K.1F 315 S4	(IE1-)K.0F 280 S4	FBW 280 IL
132.0	IE3-W.1F 315 M4	IE2-W.1F 315 M4	(IE1-)K.1F 315 M4	(IE1-)K.0F 280 M4	FBW 280 IL
160.0	IE3-W.1F 315 MX4	IE2-W.1F 315 MX4	(IE1-)K.1F 315 MX4	(IE1-)K.0F 315 S4	FBW 280 IL
200.0	IE3-W.1F 315 MY4	IE2-W.1F 315 MY4	(IE1-)K.1F 315 MY4	(IE1-)K.0F 315 M4	FBW 315 MY IL
250.0	IE3-W.1F 315 L4	IE2-W.1F 315 L4	(IE1-)K.1F 315 L4	(IE1-)K.0F 315 L4	FBW 315 MY IL
315.0	IE3-W.1F 315 LX4	IE2-W.1F 315 LX4	(IE1-)K.1F 315 LX4	(IE1-)K.0F 315 LX4	FBW 315 LX IL
315.0	-	IE2-W.2F 355 MY4	(IE1-)K.2F 355 MY4	-	FBW 355 IL
355.0	IE3-W.1F 355 M4	IE2-W.2F 355 M4	(IE1-)K.2F 355 M4	-	FBW 355 IL
400.0	IE3-W.2F 355 MX4	IE2-W.2F 355 MX4	(IE1-)K.2F 355 MX4	-	FBW 355 IL
450.0	-	IE2-W.2F 355 LY4	(IE1-)K.2F 355 LY4	-	FBW 355 IL
500.0	IE3-W.2F 355 L4	IE2-W.2F 355 L4	(IE1-)K.2F 355 L4	-	FBW 355 IL

Corresponding basic version plus fan

Motors with forced ventilation must always be provided with thermal motor protection.

Observe catalogue data regarding outputs in converter-fed operation.

In accordance with Regulation (EC) No. 640/2009, motors in 2-, 4- and 6-pole versions for outputs from 0.75 to 355 kW may only be brought onto the market if they do not fall within the scope of applicability of the regulation on account of the operating conditions specified by the customer.

(IE1-) can be supplied with and without marking of IE classification

***) upon request

Built-on fans, type of cooling IC 416, Fan unit FBW (Wistro) for squirrel-cage motors, 6-pole

Premium Efficiency IE3/High Efficiency IE2/Standard Efficiency IE1 according to IEC/EN 60034-30-1

PB kW	Series				Fan unit
	For motor IE3-	For motor IE2-	For motor (IE1-)K.1R	For motor (IE1-)K.OR	
0.12		IE2-W.2F 63 G6	***)	***)	FBW 63
0.12	IE3-W.1F 63 G6	-	***)	***)	FBW 71
0.18	IE3-W.2F 71 KY6	IE2-W.2F 71 K6	(IE1-)K.1F 71 K6	(IE1-)K.OF 63 K6	FBW 71
0.25	-	IE2-W.1F 71 G6	(IE1-)K.1F 71 G6	(IE1-)K.OF 63 G6	FBW 71
0.25	IE3-W.1F 71 GY6	-	-	-	FBW 80
0.37	-	IE2-W.1F 80 K6	(IE1-)K.1F 80 K6	(IE1-)K.OF 71 K6	FBW 80
0.37	IE3-W.1F 80 K6	-	-	-	FBW 90
0.37	-	-	(IE1-)K.1F 80 G6	(IE1-)K.OF 71 G6	FBW 80
0.55	IE3-W.1F 80 G6	IE2-W.1F 80 GY6	-	-	FBW 90
0.75	-	-	(IE1-)K.1F 90 S6	(IE1-)K.OF 80 K6	FBW 90
0.75	IE3-W.1F 90 S6	IE2-W.1F 90 S6	-	-	FBW 100
1.1	-	-	(IE1-)K.1F 90 L6	(IE1-)K.OF 80 G6	FBW 90
1.1	IE3-W.1F 90 L6	IE2-W.1F 90 L6	-	-	FBW 100
1.5	-	-	(IE1-)K.1F 100 L6	(IE1-)K.OF 90 L6	FBW 100
1.5	IE3-W.1F 100 L6	-	-	-	FBW 112
1.5	-	IE2-W.1F 100 LX6	-	-	FBW 112
2.2	IE3-W.1F 112 MZ6	IE2-W.1F 112 MV6	(IE1-)K.1F 112 M6	(IE1-)K.OF 100 L6	FBW 112
3.0	IE3-W.1F 132 S6	IE2-W.1F 132 S6	(IE1-)K.1F 132 S6T	-	FBW 112 IL
4.0	-	-	(IE1-)K.1F 132 M6	(IE1-)K.OF 112 MX6	FBW 112 IL
4.0	IE3-W.1F 132 M6	IE2-W.2F 132 M6	-	-	FBW 132 IL
5.5	IE3-W.1F 132 MX6	IE2-W.1F 132 MX6	(IE1-)K.1F 132 MX6	(IE1-)K.OF 132 S6	FBW 132 IL
7.5	-	-	(IE1-)K.1F 160 M6	(IE1-)K.OF 132 M6	FBW 132 IL
7.5	IE3-W.1F 160 M6	IE2-W.2F 160 M6	-	-	FBW 160 IL
11.0	IE3-W.1F 160 L6C	IE2-W.1F 160 L6	(IE1-)K.1F 160 L6	(IE1-)K.OF 160 S6	FBW 160 IL
15.0	-	-	(IE1-)K.1F 180 L6	(IE1-)K.OF 160 M6	FBW 160 IL
15.0	IE3-W.1F 180 L6C	IE2-W.2F 180 L6	-	-	FBW 180 IL
18.5	-	IE2-W.1F 200 L6	(IE1-)K.1F 200 L6	(IE1-)K.OF 180 S6	FBW 180 IL
18.5	-	-	(IE1-)K.1F 200 LX6	(IE1-)K.OF 180 M6	FBW 180 IL
18.5	IE3-W.1F 200 L6C	-	-	-	FBW 200 IL
22.0	IE3-W.1F 200 LX6C	IE2-W.2F 200 LX6	-	-	FBW 200 IL
30.0	-	-	(IE1-)K.1F 225 M6	(IE1-)K.OF 200 M6	FBW 200 IL
30.0	IE3-W.1F 225 M6	IE2-W.2F 225 M6	-	-	FBW 225 IL
37.0	-	-	(IE1-)K.1F 250 M6	(IE1-)K.OF 225 M6	FBW 225 IL
37.0	IE3-W.1F 250 M6	IE2-W.2F 250 M6	-	-	FBW 250 IL
45.0	-	IE2-W.2F 280 S6	(IE1-)K.1F 280 S6	(IE1-)K.OF 250 S6	FBW 250 IL
45.0	IE3-W.1F 280 S6	-	-	-	FBW 280 IL
55.0	-	-	(IE1-)K.1F 280 M6	(IE1-)K.OF 250 M6	FBW 250 IL
55.0	IE3-W.1F 280 M6	IE2-W.2F 280 M6	-	-	FBW 280 IL
75.0	IE3-W.1F 315 S6	IE2-W.2F 315 S6	(IE1-)K.1F 315 S6	(IE1-)K.OF 280 S6	FBW 280 IL
90.0	-	IE2-W.2F 315 M6	(IE1-)K.1F 315 M6	(IE1-)K.OF 280 M6	FBW 280 IL
90.0	IE3-W.1F 315 M6	-	-	-	FBW 315 MY IL
110.0	-	-	(IE1-)K.1F 315 MX6	(IE1-)K.OF 315 S6	FBW 280 IL
110.0	IE3-W.1F 315 MX6	IE2-W.1F 315 MX6	-	-	FBW 315 MY IL
132.0	-	IE2-W.1F 315 MY6	(IE1-)K.1F 315 MY6	(IE1-)K.OF 315 M6	FBW 315 MY IL
132.0	IE3-W.1F 315 L6	IE2-W.1F 315 L6	(IE1-)K.1F 315 L6	(IE1-)K.OF 315 L6	FBW 315 MY IL
200.0	-	IE2-W.1F 315 LX6	(IE1-)K.1F 315 LX6	(IE1-)K.OF 315 LX6	FBW 315 MY IL
200.0	-	IE2-W.2F 355 MY6	(IE1-)K.2F 355 MY6	-	FBW 355 IL
160.0	W.1F 355 M6	IE2-W.2F 355 M6	(IE1-)K.2F 355 M6	-	FBW 355 IL
200.0	W.2F 355 MX6	IE2-W.2F 355 MX6	(IE1-)K.2F 355 MX6	-	FBW 355 IL
250.0	W.2F 355 L6	IE2-W.2F 355 LY6	(IE1-)K.2F 355 LY6	-	FBW 355 IL

Corresponding basic version plus fan

Motors with forced ventilation must always be provided with thermal motor protection.

Observe catalogue data regarding outputs in converter-fed operation.

In accordance with Regulation (EC) No. 640/2009, motors in 2-, 4- and 6-pole versions for outputs from 0.75 to 355 kW may only be brought onto the market if they do not fall within the scope of applicability of the regulation on account of the operating conditions specified by the customer.

(IE1-) can be supplied with and without marking of IE classification

***) upon request

Built-on fans, type of cooling IC 416, Fan unit FBW (Wistro) for squirrel-cage motors, 8-pole

Premium Efficiency IE3/High Efficiency IE2/Standard Efficiency IE1 according to IEC/EN 60034-30-1

PB kW	Series				Fan unit
	For motor IE3-	For motor IE2-	For motor (IE1-)K.1R	For motor (IE1-)K.OR	
0.12	-	-	(IE1-)K.1F 71 K8	(IE1-)K.OF 63 K8	FBW 71
0.12	-	IE2-W.2F 71 G8	(IE1-)K.1F 71 G8	(IE1-)K.OF 63 G8	FBW 71
0.12	IE3-W.1F 71 G8	-	-	-	FBW 80
0.18	IE3-W.2R 80 K8	IE2-W.1F 80 K8	(IE1-)K.1F 80 K8	(IE1-)K.OF 71 K8	FBW 80
0.25	-	IE2-W.1F 80 G8	(IE1-)K.1F 80 G8	(IE1-)K.OF 71 G8	FBW 80
0.25	IE3-W.1F 80 G8	-	-	-	FBW 90
0.37	IE3-W.2F 90 S8	IE2-W.1F 90 S8	(IE1-)K.1F 90 S8	(IE1-)K.OF 80 K8	FBW 90
0.55	-	IE2-W.1F 90 L8	(IE1-)K.1F 90 L8	(IE1-)K.OF 80 G6	FBW 90
0.55	IE3-W.1F 90 L8	-	-	-	FBW 100
0.75	-	-	(IE1-)K.1F 100 L8	(IE1-)K.OF 90 L8	FBW 100
0.75	IE3-W.1F 100 LY8	IE2-W.1F 100 L8	-	-	FBW 112
1.1	IE3-W.1F 100 LV8	IE2-W.1F 100 LY8	(IE1-)K.1F 100 LX8	(IE1-)K.OF 100 S8	FBW 112
1.5	IE3-W.1F 112 M8	IE2-W.1F 112 M8	(IE1-)K.1F 112 M8	(IE1-)K.OF 100 L8	FBW 112
2.2	IE3-W.1F 132 S8	IE2-W.1F 132 S8	(IE1-)K.1F 132 S8	(IE1-)K.OF 112 M8	FBW 112 IL
3.0	-	-	(IE1-)K.1F 132 M8	(IE1-)K.OF 112 MX8	FBW 112 IL
3.0	IE3-W.1F 132 M8	IE2-W.2F 132 M8	-	-	FBW 132 IL
4.0	IE3-W.1F 160 M8	IE2-W.1F 160 M8	(IE1-)K.1F 160 M8	(IE1-)K.OF 132 S8	FBW 132 IL
5.5	-	-	(IE1-)K.1F 160 MX8	(IE1-)K.OF 132 M8	FBW 132 IL
5.5	IE3-W.1F 160 MX8	IE2-W.2F 160 MX8	-	-	FBW 160 IL
7.5	IE3-W.1F 160 L8C	IE2-W.1F 160 L8	(IE1-)K.1F 160 L8	(IE1-)K.OF 160 S8	FBW 160 IL
11.0	-	-	(IE1-)K.1F 180 L8	(IE1-)K.OF 160 M8	FBW 160 IL
11.0	IE3-W.1F 180 L8	IE2-W.2F 180 L8	-	-	FBW 180 IL
15.0	IE3-W.1F 200 L8	IE2-W.1F 200 L8	(IE1-)K.1F 200 L8	(IE1-)K.OF 180 S8	FBW 180 IL
18.5	IE3-W.1F 225 S8	IE2-W.2F 225 S8	(IE1-)K.1F 225 S8	(IE1-)K.OF 180 M8	FBW 200 IL
22.0	-	-	(IE1-)K.1F 225 M8	(IE1-)K.OF 200 M8	FBW 200 IL
22.0	IE3-W.1F 225 M8	IE2-W.2F 225 M8	-	-	FBW 225 IL
30.0	-	-	(IE1-)K.1F 250 M8	(IE1-)K.OF 225 M8	FBW 225 IL
30.0	IE3-W.1F 250 M8	IE2-W.2F 250 M8	-	-	FBW 250 IL
37.0	-	IE2-W.1F 280 S8	(IE1-)K.1F 280 S8	(IE1-)K.OF 250 S8	FBW 250 IL
37.0	IE3-W.1F 280 S8	-	-	-	FBW 280 IL
45.0	-	-	(IE1-)K.1F 280 M8	(IE1-)K.OF 250 M8	FBW 250 IL
45.0	IE3-W.1F 280 M8	IE2-W.1F 280 M8	-	-	FBW 280 IL
55.0	IE3-W.1F 315 S8	IE2-W.1F 315 S8	(IE1-)K.1F 315 S8	(IE1-)K.OF 280 S8	FBW 280 IL
75.0	-	IE2-W.1F 315 M8	(IE1-)K.1F 315 M8	(IE1-)K.OF 280 M8	FBW 280 IL
75.0	IE3-W.1F 315 M8	-	-	-	FBW 315 MY IL
90.0	-	-	(IE1-)K.1F 315 MX8	(IE1-)K.OF 315 S8	FBW 280 IL
90.0	IE3-W.1F 315 MX8	IE2-W.1F 315 MX8	-	-	FBW 315 MY IL
110.0	IE3-W.1F 315 MY8	IE2-W.1F 315 MY8	(IE1-)K.1F 315 MY8	(IE1-)K.OF 315 M8	FBW 315 MY IL
110.0	IE3-W.1F 315 L8	IE2-W.1F 315 L8	(IE1-)K.1F 315 L8	(IE1-)K.OF 315 L8	FBW 315 MY IL
160.0	-	IE2-W.1F 315 LX8	(IE1-)K.1F 315 LX8	(IE1-)K.OF 315 LX8	FBW 315 MY IL
132.0	IE3-W.1F 355 MY8	IE2-W.2F 355 MY8	(IE1-)K.2F 355 MY8	-	FBW 355 IL
132.0	IE3-W.1F 355 M8	IE2-W.2F 355 M8	(IE1-)K.2F 355 M8	-	FBW 355 IL
160.0	IE3-W.2F 355 MX8	IE2-W.2F 355 MX8	(IE1-)K.2F 355 MX8	-	FBW 355 IL
200.0	IE3-W.2F 355 L8	IE2-W.2F 355 LY8	(IE1-)K.2F 355 LY8	-	FBW 355 IL

Corresponding basic version plus fan

Motors with forced ventilation must always be provided with thermal motor protection.

Observe catalogue data regarding outputs in converter-fed operation.

In accordance with Regulation (EC) No. 640/2009, motors in 2-, 4- and 6-pole versions for outputs from 0.75 to 355 kW may only be brought onto the market if they do not fall within the scope of applicability of the regulation on account of the operating conditions specified by the customer. (IE1-) can be supplied with and without marking of IE classification

Built-on fans, type of cooling IC 416, Fan unit FBI/MMP (Maier) for squirrel-cage motors, 2-pole

Premium Efficiency IE3/High Efficiency IE2/Standard Efficiency IE1 according to IEC/EN 60034-30-1

PB kW	Series				Fan unit
	For motor IE3-	For motor IE2-	For motor (IE1-)K.1R	For motor (IE1-)K.OR	
0.12	IE3-W.1F 56 G2	IE2-W.2F 56 G2	***)	***)	FBI 63-2
0.18	IE3-W.2F 63 K2	IE2-W.2F 63 K2	***)	***)	FBI 63-2
0.25	-	IE2-W.2F 63 G2	***)	***)	FBI 63-2
0.25	IE3-W.1F 63 G2	-	***)	***)	FBI 63-2
0.37	-	-	(IE1-)K.1F 71 K2	(IE1-)K.OF 63 K2	FBI 63-2
0.37	-	IE2-W.1F 71 K2	-	-	FBI 71-2
0.55	-	-	(IE1-)K.1F 71 G2	(IE1-)K.OF 63 G2	FBI 63-2
0.55	-	IE2-W.1F 71 G2	-	-	FBI 71-2
0.75	-	-	(IE1-)K.1F 80 K2	(IE1-)K.OF 71 K2	FBI 71-2
0.75	IE3-W.1F 80 K2	IE2-W.1F 80 K2	-	-	FBI 80-2
1.1	-	-	(IE1-)K.1F 80 G2	(IE1-)K.OF 71 G2	FBI 71-2
1.1	IE3-W.1F 80 G2	IE2-W.1F 80 G2	-	-	FBI 80-2
1.5	-	-	(IE1-)K.1F 90 S2	(IE1-)K.OF 80 K2	FBI 80-2
1.5	IE3-W.1F 90 S2	IE2-W.1F 90 S2	-	-	FBI 90-2
2.2	-	-	(IE1-)K.1F 90 L2	(IE1-)K.OF 80 G2	FBI 80-2
2.2	IE3-W.1F 90 L2	IE2-W.1F 90 L2	-	-	FBI 90-2
3.0	-	-	(IE1-)K.1F 100 L2	(IE1-)K.OF 90 L2	FBI 90-2
3.0	IE3-W.1F 100 L2	IE2-W.1F 100 L2	-	-	FBI 100-2
4.0	-	-	(IE1-)K.1F 112 M2	(IE1-)K.OF 100 S2	FBI 100-2
4.0	IE3-W.1F 112 M2	IE2-W.1F 112 MX2	(IE1-)K.1F 112 MX2	(IE1-)K.OF 100 L2	FBI 100-2
5.5	-	-	(IE1-)K.1F 132 S2T	-	FBI 100-2
5.5	IE3-W.1F 132 S2	IE2-W.1F 132 S2T	-	-	FBI 112-2
7.5	-	-	(IE1-)K.1F 132 SX2T	-	FBI 100-2
7.5	IE3-W.1F 132 SX2	-	-	-	FBI 132-2
11.0	IE3-W.1F 160 M2	IE2-W.1F 160 M2	(IE1-)K.1F 160 M2	(IE1-)K.OF 132 M2	FBI 160-2
15.0	IE3-W.1F 160 MX2	IE2-W.1F 160 MX2	(IE1-)K.1F 160 MX2	(IE1-)K.OF 160 S2	FBI 160-2
18.5	IE3-W.1F 160 L2	IE2-W.1F 160 L2	(IE1-)K.1F 160 L2	(IE1-)K.2R 160 M2	FBI 160-2
22.0	IE3-W.1F 180 M2C	IE2-W.1F 180 M2	(IE1-)K.1F 180 M2	(IE1-)K.OF 180 S2	FBI 180-2
30.0	-	IE2-W.1F 200 L2	(IE1-)K.1F 200 L2	(IE1-)K.OF 180 M2	FBI 200-2
30.0	IE3-W.1F 200 L2	-	-	-	FBI 180-2
37.0	IE3-W.1F 200 LX2C	IE2-W.1F 200 LX2	(IE1-)K.1F 200 LX2	(IE1-)K.OF 200 M2	FBI 180-2
45.0	-	IE2-W.1F 225 M2	(IE1-)K.1F 225 M2	(IE1-)K.OF 200 L2	FBI 200-2
45.0	IE3-W.1F 225 M2	-	-	-	-
55.0	-	IE2-W.1F 250 M2	(IE1-)K.1F 250 M2	(IE1-)K.OF 225 M2	FBI 250-4
55.0	IE3-W.1F 250 M2	-	-	-	FBI 280-25
75.0	IE3-W.1F 280 S2	IE2-W.1F 280 S2	(IE1-)K.1F 280 S2	(IE1-)K.OF 250 S2	FBI 280-13
90.0	IE3-W.1F 280 M2	IE2-W.1F 280 M2	(IE1-)K.1F 280 M2	(IE1-)K.OF 250 M2	FBI 280-13
110.0	IE3-W.1F 315 S2	IE2-W.1F 315 S2	(IE1-)K.1F 315 S2	(IE1-)K.OF 280 S2	FBI 315-14
132.0	IE3-W.1F 315 M2	IE2-W.1F 315 M2	(IE1-)K.1F 315 M2	(IE1-)K.OF 280 M2	FBI 315-14
160.0	IE3-W.1F 315 MX2	IE2-W.1F 315 MX2	(IE1-)K.1F 315 MX2	(IE1-)K.OF 315 S2	FBI 315-14
200.0	IE3-W.1F 315 MY2	IE2-W.1F 315 MY2	(IE1-)K.1F 315 MY2	(IE1-)K.OF 315 M2	FBI 315-23
250.0	IE3-W.1F 315 L2	IE2-W.1F 315 L2	(IE1-)K.1F 315 L2	(IE1-)K.OF 315 L2	FBI 315-23
315.0	IE3-W.1F 315 LX2	IE2-W.1F 315 LX2	(IE1-)K.1F 315 LX2	(IE1-)K.OF 315 LX2	FBI 315-24
315.0	-	IE2-W.2F 355 MY2	(IE1-)K.2F 355 MY2	-	FBI 355-26
355.0	IE3-W.1F 355 M2	IE2-W.2F 355 M2	(IE1-)K.2F 355 M2	-	FBI 355-26
400.0	IE3-W.2F 355 MX2	IE2-W.2F 355 MX2	(IE1-)K.2F 355 MX2	-	FBI 355-26
450.0	-	IE2-W.2F 355 LY2	(IE1-)K.2F 355 LY2	-	FBI 355-26
500.0	IE3-W.2F 355 L2	IE2-W.2F 355 L2	(IE1-)K.2F 355 L2	-	FBI 355-26

Corresponding basic version plus fan

Motors with forced ventilation must always be provided with thermal motor protection.

Observe catalogue data regarding outputs in converter-fed operation.

In accordance with Regulation (EC) No. 640/2009, motors in 2-, 4- and 6-pole versions for outputs from 0.75 to 355 kW may only be brought onto the market if they do not fall within the scope of applicability of the regulation on account of the operating conditions specified by the customer.

(IE1-) can be supplied with and without marking of IE classification

***) upon request

Built-on fans, type of cooling IC 416, Fan unit FBI/MMP (Maier) for squirrel-cage motors, 4-pole

Premium Efficiency IE3/High Efficiency IE2/Standard Efficiency IE1 according to IEC/EN 60034-30-1

PB kW	Series				Fan unit
	For motor IE3-	For motor IE2-	For motor (IE1-)K.1R	For motor (IE1-)K.OR	
0.12	IE3-W.2F 63 K4	IE2-W.2F 63 K4	***)	***)	***)
0.18	IE3-W.1F 63 G4	IE2-W.1F 63 GY4	***)	***)	***)
0.25	-	-	(IE1-)K.1F 71 K4	(IE1-)K.OF 63 K4	FBI 63-2
0.25	-	IE2-W.1F 71 K4	-	-	FBI 71-2
0.37	-	-	(IE1-)K.1F 71 G4	(IE1-)K.OF 63 G4	FBI 63-2
0.37	IE3-W.1F 71 GY4	IE2-W.1F 71 GY4	-	-	FBI 71-2
0.55	-	-	(IE1-)K.1F 80 K4	(IE1-)K.OF 71 K4	FBI 71-2
0.55	-	IE2-W.1F 80 K4	-	-	FBI 80-2
0.75	-	-	(IE1-)K.1F 80 G4	(IE1-)K.OF 71 G4	FBI 71-2
0.75	IE3-W.1F 80 GX4	IE2-W.1F 80 G4	-	-	FBI 80-2
1.1	-	-	(IE1-)K.1F 90 S4	(IE1-)K.OF 80 K4	FBI 80-2
1.1	IE3-W.1F 90 S4	IE2-W.1F 90 S4	-	-	FBI 90-2
1.5	-	-	(IE1-)K.1F 90 L4	(IE1-)K.OF 80 G4	FBI 80-2
1.5	IE3-W.1F 90 LX4	IE2-W.1F 90 L4	-	-	FBI 90-2
2.2	-	-	(IE1-)K.1F 100 L4	(IE1-)K.OF 90 L4	FBI 90-2
2.2	IE3-W.1F 100 L4	IE2-W.1F 100 L4	-	-	FBI 100-2
3.0	IE3-W.1F 100 LZ4	IE2-W.1F 100 LX4	(IE1-)K.1F 100 LX4	(IE1-)K.OF 100 S4	FBI 100-2
4.0	-	IE2-W.1F 112 MZ4	(IE1-)K.1F 112 M4	(IE1-)K.OF 100 L4	FBI 100-2
4.0	IE3-W.1F 112 M4	IE2-W.1F 112 M4	-	-	FBI 112-2
5.5	-	-	(IE1-)K.1F 132 S4	(IE1-)K.OF 112 M4	FBI 100-2
5.5	IE3-W.1F 132 S4	IE2-W.2F 132 S4	-	-	FBI 112-2
7.5	-	-	(IE1-)K.1F 132 M4	(IE1-)K.OF 132 S4	FBI 132-2
7.5	IE3-W.1F 132 M4	-	-	-	FBI 112-2
7.5	-	IE2-W.1F 132 M4	-	-	FBI 132-2
11.0	IE3-W.1F 160 M4	IE2-W.2F 160 M4	(IE1-)K.1F 160 M4	(IE1-)K.OF 132 M4	FBI 132-2
15.0	IE3-W.1F 160 L4C	IE2-W.2F 160 L4	(IE1-)K.1F 160 L4	(IE1-)K.OF 160 S4	FBI 132-2
18.5	-	-	(IE1-)K.1F 180 M4	(IE1-)K.OF 160 M4	FBI 160-2
18.5	IE3-W.1F 180 M4	IE2-W.1F 180 M4	-	-	FBI 180-2
22.0	IE3-W.1F 180 L4	IE2-W.1F 180 L4	(IE1-)K.1F 180 L4	(IE1-)K.OF 180 S4	FBI 180-2
30.0	-	-	(IE1-)K.1F 200 L4	(IE1-)K.OF 180 M4	FBI 200-2
30.0	IE3-W.1F 200 L4C	IE2-W.1F 200 L4	-	-	FBI 180-2
37.0	IE3-W.1F 225 S4C	IE2-W.1F 225 S4	(IE1-)K.1F 225 S4	(IE1-)K.OF 200 M4	FBI 200-4
45.0	-	-	(IE1-)K.1F 225 M4	(IE1-)K.OF 200 L4	FBI 200-4
45.0	IE3-W.1F 225 M4	IE2-W.2F 225 M4	-	-	-
55.0	-	IE2-W.2F 250 M4	(IE1-)K.1F 250 M4	(IE1-)K.OF 225 M4	FBI 250-4
55.0	IE3-W.1F 250 M4	-	-	-	FBI 280-25
75.0	IE3-W.1F 280 S4	IE2-W.1F 280 S4	(IE1-)K.1F 280 S4	(IE1-)K.OF 250 S4	FBI 280-13
90.0	-	IE2-W.1F 280 M4	(IE1-)K.1F 280 M4	(IE1-)K.OF 250 M4	FBI 280-13
90.0	IE3-W.1F 280 M4	-	-	-	-
110.0	IE3-W.1F 315 S4	IE2-W.1F 315 S4	(IE1-)K.1F 315 S4	(IE1-)K.OF 280 S4	FBI 315-14
132.0	IE3-W.1F 315 M4	IE2-W.1F 315 M4	(IE1-)K.1F 315 M4	(IE1-)K.OF 280 M4	FBI 315-14
160.0	IE3-W.1F 315 MX4	IE2-W.1F 315 MX4	(IE1-)K.1F 315 MX4	(IE1-)K.OF 315 S4	FBI 315-14
200.0	IE3-W.1F 315 MY4	IE2-W.1F 315 MY4	(IE1-)K.1F 315 MY4	(IE1-)K.OF 315 M4	FBI 315-23
250.0	IE3-W.1F 315 L4	IE2-W.1F 315 L4	(IE1-)K.1F 315 L4	(IE1-)K.OF 315 L4	FBI 315-23
315.0	IE3-W.1F 315 LX4	IE2-W.1F 315 LX4	(IE1-)K.1F 315 LX4	(IE1-)K.OF 315 LX4	FBI 315-24
315.0	-	IE2-W.2F 355 MY4	(IE1-)K.2F 355 MY4	-	FBI 355-26
355.0	IE3-W.1F 355 M4	IE2-W.2F 355 M4	(IE1-)K.2F 355 M4	-	FBI 355-26
400.0	IE3-W.2F 355 MX4	IE2-W.2F 355 MX4	(IE1-)K.2F 355 MX4	-	FBI 355-26
450.0	-	IE2-W.2F 355 LY4	(IE1-)K.2F 355 LY4	-	FBI 355-26
500.0	IE3-W.2F 355 L4	IE2-W.2F 355 L4	(IE1-)K.2F 355 L4	-	FBI 355-26

Corresponding basic version plus fan

Motors with forced ventilation must always be provided with thermal motor protection.

Observe catalogue data regarding outputs in converter-fed operation.

In accordance with Regulation (EC) No. 640/2009, motors in 2-, 4- and 6-pole versions for outputs from 0.75 to 355 kW may only be brought onto the market if they do not fall within the scope of applicability of the regulation on account of the operating conditions specified by the customer.

(IE1-) can be supplied with and without marking of IE classification

***) upon request

Built-on fans, type of cooling IC 416, Fan unit FBI/MMP (Maier) for squirrel-cage motors, 6-pole

Premium Efficiency IE3/High Efficiency IE2/Standard Efficiency IE1 according to IEC/EN 60034-30-1

PB kW	Series				Fan unit
	For motor IE3-	For motor IE2-	For motor (IE1-)K.1R	For motor (IE1-)K.OR	
0.12	-	IE2-W.2F 63 G6	***)	***)	***)
0.12	IE3-W.1F 63 G6	-	***)	***)	***)
0.18	IE3-W.2F 71 KY6	IE2-W.2F 71 K6	***)	***)	***)
0.18	-	-	(IE1-)K.1F 71 K6	(IE1-)K.OF 63 K6	FBI 63-2
0.25	-	-	(IE1-)K.1F 71 G6	(IE1-)K.OF 63 G6	FBI 63-2
0.25	-	IE2-W.1F 71 G6	***)	***)	***)
0.25	IE3-W.1F 71 GY6	-	-	-	FBI 71-2
0.37	-	-	(IE1-)K.1F 80 K6	(IE1-)K.OF 71 K6	FBI 71-2
0.37	-	IE2-W.1F 80 K6	-	-	FBI 80-2
0.55	-	-	(IE1-)K.1F 80 G6	(IE1-)K.OF 71 G6	FBI 71-2
0.55	-	IE2-W.1F 80 GY6	-	-	FBI 80-2
0.75	-	-	(IE1-)K.1F 90 S6	(IE1-)K.OF 80 K6	FBI 80-2
0.75	IE3-W.1F 90 S6	IE2-W.1F 90 S6	-	-	FBI 90-2
1.1	-	-	(IE1-)K.1F 90 L6	(IE1-)K.OF 80 G6	FBI 80-2
1.1	IE3-W.1F 90 L6	IE2-W.1F 90 L6	-	-	FBI 90-2
1.5	-	-	(IE1-)K.1F 100 L6	(IE1-)K.OF 90 L6	FBI 90-2
1.5	IE3-W.1F 100 L6	IE2-W.1F 100 LX6	-	-	FBI 100-2
2.2	IE3-W.1F 112 MZ6	IE2-W.1F 112 MV6	(IE1-)K.1F 112 M6	(IE1-)K.OF 100 L6	FBI 100-2
3.0	-	-	(IE1-)K.1F 132 S6T	-	FBI 100-2
3.0	IE3-W.1F 132 S6	IE2-W.1F 132 S6	-	-	FBI 112-2
4.0	IE3-W.1F 132 M6	IE2-W.2F 132 M6	(IE1-)K.1F 132 M6	(IE1-)K.OF 112 MX6	FBI 112-2
5.5	IE3-W.1F 132 MX6	IE2-W.1F 132 MX6	(IE1-)K.1F 132 MX6	(IE1-)K.OF 132 S6	FBI 112-2
7.5	IE3-W.1F 160 M6	IE2-W.2F 160 M6	(IE1-)K.1F 160 M6	(IE1-)K.OF 132 M6	FBI 132-2
11.0	-	-	(IE1-)K.1F 160 L6	(IE1-)K.OF 160 S6	FBI 160-2
11.0	IE3-W.1F 160 L6C	IE2-W.1F 160 L6	-	-	FBI 132-2
15.0	-	-	(IE1-)K.1F 180 L6	(IE1-)K.OF 160 M6	FBI 160-2
15.0	IE3-W.1F 180 L6C	IE2-W.2F 180 L6	-	-	FBI 180-2
18.5	-	IE2-W.1F 200 L6	(IE1-)K.1F 200 L6	(IE1-)K.OF 180 S6	FBI 200-2
18.5	-	-	(IE1-)K.1F 200 LX6	(IE1-)K.OF 180 M6	FBI 200-2
18.5	IE3-W.1F 200 L6C	-	-	-	FBI 180-2
22.0	IE3-W.1F 200 LX6C	IE2-W.2F 200 LX6	-	-	FBI 180-2
30.0	-	-	(IE1-)K.1F 225 M6	(IE1-)K.OF 200 M6	FBI 200-4
30.0	IE3-W.1F 225 M6	IE2-W.2F 225 M6	-	-	-
37.0	-	-	(IE1-)K.1F 250 M6	(IE1-)K.OF 225 M6	FBI 250-4
37.0	IE3-W.1F 250 M6	IE2-W.2F 250 M6	-	-	FBI 280-25
45.0	-	IE2-W.2F 280 S6	(IE1-)K.1F 280 S6	(IE1-)K.OF 250 S6	FBI 280-13
45.0	IE3-W.1F 280 S6	-	-	-	-
55.0	-	-	(IE1-)K.1F 280 M6	(IE1-)K.OF 250 M6	FBI 280-13
55.0	IE3-W.1F 280 M6	IE2-W.2F 280 M6	-	-	-
75.0	IE3-W.1F 315 S6	IE2-W.2F 315 S6	(IE1-)K.1F 315 S6	(IE1-)K.OF 280 S6	FBI 315-14
90.0	-	IE2-W.2F 315 M6	(IE1-)K.1F 315 M6	(IE1-)K.OF 280 M6	FBI 315-14
90.0	IE3-W.1F 315 M6	-	-	-	FBI 315-23
110.0	-	-	(IE1-)K.1F 315 MX6	(IE1-)K.OF 315 S6	FBI 315-14
110.0	IE3-W.1F 315 MX6	IE2-W.1F 315 MX6	-	-	FBI 315-23
132.0	-	IE2-W.1F 315 MY6	(IE1-)K.1F 315 MY6	(IE1-)K.OF 315 M6	FBI 315-23
132.0	IE3-W.1F 315 L6	IE2-W.1F 315 L6	(IE1-)K.1F 315 L6	(IE1-)K.OF 315 L6	FBI 315-23
200.0	-	IE2-W.1F 315 LX6	(IE1-)K.1F 315 LX6	(IE1-)K.OF 315 LX6	FBI 315-23
200.0	-	IE2-W.2F 355 MY6	(IE1-)K.2F 355 MY6	-	FBI 355-26
160.0	W.1F 355 M6	IE2-W.2F 355 M6	(IE1-)K.2F 355 M6	-	FBI 355-26
200.0	W.2F 355 MX6	IE2-W.2F 355 MX6	(IE1-)K.2F 355 MX6	-	FBI 355-26
250.0	W.2F 355 L6	IE2-W.2F 355 LY6	(IE1-)K.2F 355 LY6	-	FBI 355-26

Corresponding basic version plus fan

Motors with forced ventilation must always be provided with thermal motor protection.

Observe catalogue data regarding outputs in converter-fed operation.

In accordance with Regulation (EC) No. 640/2009, motors in 2-, 4- and 6-pole versions for outputs from 0.75 to 355 kW may only be brought onto the market if they do not fall within the scope of applicability of the regulation on account of the operating conditions specified by the customer.

(IE1-) can be supplied with and without marking of IE classification

***) upon request

Built-on fans, type of cooling IC 416, Fan unit FBI/MMP (Maier) for squirrel-cage motors, 8-pole

Premium Efficiency IE3/High Efficiency IE2/Standard Efficiency IE1 according to IEC/EN 60034-30-1

PB kW	Series				Fan unit
	For motor IE3-	For motor IE2-	For motor (IE1-)K.1R	For motor (IE1-)K.OR	
0.09	-	-	(IE1-)K.1F 71 K8	(IE1-)K.OF 63 K8	FBI 63-2
0.12	-	IE2-W.2F 71 G8	(IE1-)K.1F 71 G8	(IE1-)K.OF 63 G8	FBI 63-2
0.12	IE3-W.1F 71 G8	-	-	-	***)
0.18	-	-	(IE1-)K.1F 80 K8	(IE1-)K.OF 71 K8	FBI 71-2
0.18	IE3-W.2F 80 K8	IE2-W.1F 80 K8	-	-	FBI 80-2
0.25	-	-	(IE1-)K.1F 80 G8	(IE1-)K.OF 71 G8	FBI 71-2
0.25	-	IE2-W.1F 80 G8	-	-	FBI 80-2
0.25	IE3-W.1F 80 G8	-	-	-	***)
0.37	-	-	(IE1-)K.1F 90 S8	(IE1-)K.OF 80 K8	FBI 80-2
0.37	IE3-W.2F 90 S8	IE2-W.1F 90 S8	-	-	FBI 90-2
0.55	-	-	(IE1-)K.1F 90 L8	(IE1-)K.OF 80 G8	FBI 80-2
0.55	-	IE2-W.1F 90 L8	-	-	FBI 90-2
0.55	IE3-W.1F 90 L8	-	-	-	***)
0.75	-	-	(IE1-)K.1F 100 L8	(IE1-)K.OF 90 L8	FBI 90-2
0.75	IE3-W.1F 100 LY8	IE2-W.1F 100 L8	-	-	FBI 100-2
1.1	IE3-W.1F 100 LV8	IE2-W.1F 100 LY8	(IE1-)K.1F 100 LX8	(IE1-)K.OF 100 S8	FBI 100-2
1.5	IE3-W.1F 112 M8	IE2-W.1F 112 MV8	(IE1-)K.1F 112 M8	(IE1-)K.OF 100 L8	FBI 100-2
		-	(IE1-)K.1F 112 MX8	-	FBI 100-2
2.2	IE3-W.1F 132 S8	IE2-W.1F 132 S8	(IE1-)K.1F 132 S8T	(IE1-)K.OF 112 M8	FBI 100-2
3.0	IE3-W.1F 132 M8	IE2-W.2F 132 M8	(IE1-)K.1F 132 M8	(IE1-)K.OF 112 MX8	FBI 112-2
4.0	IE3-W.1F 160 M8	IE2-W.1F 160 M8	(IE1-)K.1F 160 M8	(IE1-)K.OF 132 S8	FBI 132-2
5.5	-	-	(IE1-)K.1F 160 MX8	(IE1-)K.OF 132 M8	FBI 132-2
5.5	IE3-W.1F 160 MX8	IE2-W.2F 160 MX8	-	-	FBI 132-2
7.5	-	-	(IE1-)K.1F 160 L8	(IE1-)K.OF 160 S8	FBI 160-2
7.5	IE3-W.1F 160 L8C	IE2-W.1F 160 L8	-	-	FBI 132-2
11.0	-	-	(IE1-)K.1F 180 L8	(IE1-)K.OF 160 M8	FBI 160-2
11.0	IE3-W.1F 180 L8	IE2-W.2F 180 L8	-	-	FBI 180-2
15.0	IE3-W.1F 200 L8	IE2-W.1F 200 L8	(IE1-)K.1F 200 L8	(IE1-)K.OF 180 S8	FBI 200-2
18.5	IE3-W.1F 225 S8	IE2-W.2F 225 S8	(IE1-)K.1F 225 S8	(IE1-)K.OF 180 M8	FBI 200-4
18.5	-	-	(IE1-)K.1F 225 M8	(IE1-)K.OF 200 M8	FBI 200-4
22.0	IE3-W.1F 225 M8	IE2-W.2F 225 M8	-	-	-
30.0	-	-	(IE1-)K.1F 250 M8	(IE1-)K.OF 225 M8	FBI 250-4
30.0	IE3-W.1F 250 M8	IE2-W.2F 250 M8	-	-	FBI 280-25
37.0	-	IE2-W.1F 280 S8	(IE1-)K.1F 280 S8	(IE1-)K.OF 250 S8	FBI 280-25
45.0	-	-	(IE1-)K.1F 280 M8	(IE1-)K.OF 250 M8	FBI 280-25
37.0	IE3-W.1F 280 S8	-	-	-	-
45.0	IE3-W.1F 280 M8	IE2-W.1F 280 M8	-	-	-
55.0	IE3-W.1F 315 S8	IE2-W.1F 315 S8	(IE1-)K.1F 315 S8	(IE1-)K.OF 280 S8	FBI 315-14
75.0	-	IE2-W.1F 315 M8	(IE1-)K.1F 315 M8	(IE1-)K.OF 280 M8	FBI 315-14
75.0	IE3-W.1F 315 M8	-	-	-	FBI 315-23
90.0	-	-	(IE1-)K.1F 315 MX8	(IE1-)K.OF 315 S8	FBI 315-14
90.0	IE3-W.1F 315 MX8	IE2-W.1F 315 MX8	-	-	FBI 315-23
110.0	IE3-W.1F 315 MY8	IE2-W.1F 315 MY8	(IE1-)K.1F 315 MY8	(IE1-)K.OF 315 M8	FBI 315-23
110.0	IE3-W.1F 315 L8	IE2-W.1F 315 L8	(IE1-)K.1F 315 L8	(IE1-)K.OF 315 L8	FBI 315-23
160.0	-	IE2-W.1F 315 LX8	(IE1-)K.1F 315 LX8	(IE1-)K.OF 315 LX8	FBI 315-23
132.0	IE3-W.1F 355 MY8	IE2-W.2F 355 MY8	(IE1-)K.2F 355 MY8	-	FBI 355-26
132.0	IE3-W.1F 355 M8	IE2-W.2F 355 M8	(IE1-)K.2F 355 M8	-	FBI 355-26
160.0	IE3-W.2F 355 MX8	IE2-W.2F 355 MX8	(IE1-)K.2F 355 MX8	-	FBI 355-26
200.0	IE3-W.2F 355 L8	IE2-W.2F 355 LY8	(IE1-)K.2F 355 LY8	-	FBI 355-26

Corresponding basic version plus fan

Motors with forced ventilation must always be provided with thermal motor protection.

Observe catalogue data regarding outputs in converter-fed operation.

In accordance with Regulation (EC) No. 640/2009, motors in 2-, 4- and 6-pole versions for outputs from 0.75 to 355 kW may only be brought onto the market if they do not fall within the scope of applicability of the regulation on account of the operating conditions specified by the customer.

(IE1-) can be supplied with and without marking of IE classification

***) upon request

VEM Holding GmbH

Pirnaer Landstraße 176
01257 Dresden
Germany

Sales

Low voltage department

Tel. +49 3943 68-3127
Fax +49 3943 68-2440
E-mail: low-voltage@vem-group.com

High voltage department

Tel. +49 351 208-3237
Fax +49 351 208-1108
E-mail: high-voltage@vem-group.com

Drive systems department

Tel. +49 351 208-1180
Fax +49 351 208-1185
E-mail: drive-systems@vem-group.com

VEM Service

Tel. +49 351 208-3237
Fax +49 351 208-1108
E-mail: service@vem-group.com



For detailed information
please visit our website.

www.vem-group.com